

Serie MDK-B

Sealless Chemical Magnetic Drive Pump Close-coupled design

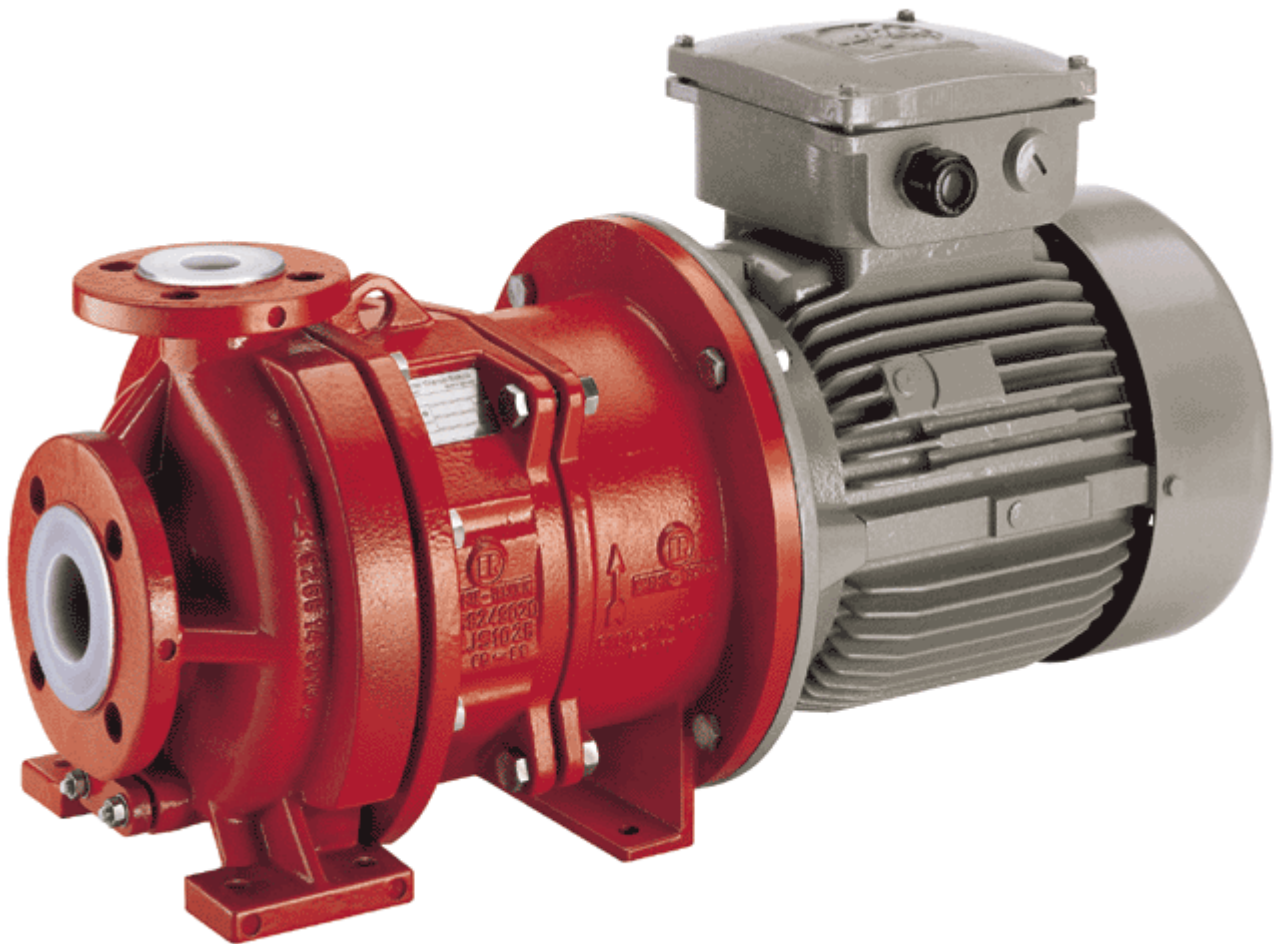

Keep for future use!

This operating manual must be strictly observed before transport, installation, operation and maintenance.

Subject to change without notice.

Reproduction is generally permitted with indication of the source.

© Richter Chemie-Technik GmbH

9260-055-en Revision 11 Edition 07/2010

List of Contents

| | | | |
|--|-----------|--|-----------|
| List of Contents | 2 | 6 Commissioning/Shutdown..... | 13 |
| Relevant documents..... | 3 | 6.1 Initial commissioning..... | 13 |
| 1 Technical data..... | 3 | 6.1.1 Filling the pump housing | 13 |
| 1.1 Tightening torques..... | 4 | 6.1.2 Start-up..... | 13 |
| 1.2 Type plate, dry-running, ATEX- and housing markings..... | 4 | 6.2 Operating limits | 13 |
| 1.3 Spare parts..... | 4 | 6.2.1 Abrasive media..... | 13 |
| 2 Notes on safety | 5 | 6.2.2 Min./max. flow rate | 13 |
| 2.1 Intended use..... | 5 | 6.3 Shutdown | 13 |
| 2.2 For the customer/operator..... | 6 | 6.4 Restarting..... | 14 |
| 2.3 For maintenance | 6 | 6.5 Improper operations and their consequences (examples) | 14 |
| 2.4 Conversion work and production of spare parts by the customer..... | 6 | 7 Maintenance | 14 |
| 2.5 Improper operation | 6 | 7.1 Screw connections of the housing..... | 14 |
| 2.6 Special requirements for explosion protection | 6 | 7.2 Motor | 14 |
| 2.6.1 Filling the unit | 6 | 7.3 Cleaning..... | 14 |
| 2.6.2 Special operating conditions | 6 | 7.4 Stand-by pumps..... | 15 |
| 2.6.3 Chargeable liquids | 7 | 7.5 Notes on dismantling | 15 |
| 2.6.4 Identification | 7 | 7.5.1 Protective clothing..... | 15 |
| 2.6.5 Check of the direction of rotation | 7 | 7.5.2 Magnetic fields | 15 |
| 2.6.6 Mode of operation of the pump | 7 | 7.5.3 Changing the motor..... | 15 |
| 2.6.7 Temperature limits | 7 | 7.6 Dismantling | 15 |
| 2.6.8 Maintenance..... | 8 | 7.6.1 Removal of motor, adapter and drive magnet assembly | 15 |
| 2.6.9 Electric peripheral equipment..... | 8 | 7.6.2 Dismantling motor, adapter and drive magnet assembly | 15 |
| 3 Transport and storage..... | 9 | 7.6.3 Dismantling slide-in unit | 16 |
| 3.1 Return consignments | 9 | 7.6.4 Dismantling housing/shaft spider | 16 |
| 3.2 Disposal..... | 9 | 7.7 Notes on assembly | 16 |
| 4 Product description..... | 10 | 7.7.1 Table for target dimension Z | 17 |
| 5 Installation..... | 10 | 7.8 Assembly..... | 18 |
| 5.1 Safety regulations..... | 10 | 7.8.1 Assembly of housing / shaft spider | 18 |
| 5.2 Installation of pump - unit | 10 | 7.8.2 Assembly of slide-in unit..... | 18 |
| 5.3 Alignment of pump - motor..... | 10 | 7.8.3 Final assembly | 18 |
| 5.4 Piping..... | 10 | 7.9 Tests | 19 |
| 5.4.1 Nominal size..... | 11 | 8 Faults | 19 |
| 5.4.2 Nozzle loads..... | 11 | 9 Sectional drawing | 20 |
| 5.4.3 Suction line..... | 11 | 9.1 MDK-B (close- coupled design) | 20 |
| 5.4.4 Supply lines..... | 11 | | |
| 5.4.5 Discharge line | 11 | | |
| 5.4.6 Venting and draining | 11 | | |
| 5.5 Pipe fittings..... | 11 | | |
| 5.6 Monitoring facilities..... | 12 | | |
| 5.7 Drive | 12 | | |
| 5.8 Electric connection | 12 | | |

Relevant documents

- ◆ Data sheet
- ◆ Works certificate
- ◆ Sectional drawing MDK-B 9260-00-3002
- ◆ Installation drawing
- ◆ Performance curves
- ◆ Spare parts list
- ◆ Operating manual and declaration of conformity motor

Appendix to the operating manual

- ◆ Operational limits 9260-00-1030
- ◆ Declaration of conformity with ATEX
- ◆ Declaration of conformity without ATEX
- ◆ Form for Safety Information Concerning the Contamination QM 0912-16-2001_en

On request:

- ◆ Magnetic drive data Richter TIS 0543-03-0001
- ◆ Publication: "Centrifugal Pump Operation without NPSH Problems"
- ◆ Publication "Safe Operation of Magnetic Drive Pumps"

1 Technical data

Manufacturer :

Richter Chemie-Technik GmbH
 Otto-Schott-Str. 2
 D-47906 Kempen
 Telephone: +49 (0) 2152 146-0
 Fax: +49 (0) 2152 146-190
 E-Mail: richter-info@idexcorp.com
 Internet: <http://www.richter-ct.com>

Authorised person acc. to machinery directive 2006/42/EG: Gregor Kleining

Designation:

Single-stage, plastic-lined, magnetic drive chemical centrifugal pump, series MDK-B, close coupled design
 Horizontal design, sealless, free of eddy currents
 Technical specifications to ISO 15783 and DIN ISO 5199

Connecting dimensions to ISO 2858 / DIN EN 22858

Flange connecting dimensions:

DIN EN 1092-2, type B (ISO 7005-2, type B) PN 16 or flanges drilled to ASME B16.5 Class 150
 ATEX 95 Directive 94/9/EC
 Machine Directive 2006/42/EC

Materials:

Pressure-bearing parts:

ductile cast iron EN-JS 1049 to DIN EN 1563 (0.7043 DIN 1693), carbon fibre composite material

Wetted parts:

PFA, SSiC, FKM/FFKM, PTFE-carbon and see data sheet.

Flow rate : up to 90 m³/h (at 2900 min⁻¹)

Delivery head : up to 80 m LC (at 2900 min⁻¹)

Housing discharge pressure : max. 16 bar
 (12 bar at -10°C to -60°C)

Temperature range : - 60 °C to + 120 °C

Temperature classes : see Section 2.6.7

Noise capacity level : L_{WA} = ≤ 70 dB acc. to DIN EN ISO 9614-2

Admissible ambient conditions for pumps acc. to directive 94/9/ EG (ATEX 95) :

Ambient temperature range: - 20 °C to + 40 °C
 (higher temperature after consulting the manufacturer)

Ambient pressure range: 0,8 bar_{abs} to 1,1 bar_{abs}

Sizes :

| Group 1.1 | Group 1.2 | Group 1.3 |
|-----------|-----------|-----------|
| 25-25-125 | 25-25-160 | 50-32-200 |
| 50-32-125 | 50-32-160 | 65-40-200 |
| | 80-50-160 | 80-50-200 |

Weight : See data sheet

Dimensions: See installation drawing

1.1 Tightening torques

Screws greased, tighten in diametrically opposite sequence

Housing screws 901/3

| Size [mm] | No. x size [DIN/ISO] | Tightening torque [Nm] |
|-----------|----------------------|------------------------|
| 25-25-125 | 8 x M 10 | 35 |
| 50-32-125 | 8 x M 10 | 35 |
| 25-25-160 | 8 x M 12 | 40 |
| 50-32-160 | 8 x M 12 | 40 |
| 80-50-160 | 8 x M 12 | 40 |
| 50-32-200 | 10x M 12 | 40 |
| 65-40-200 | 10x M 12 | 40 |
| 80-50-200 | 10 x M 12 | 40 |

Pipe screws, flanges to DIN/ISO

| DN [mm] | No. x size [DIN/ISO] | Tightening torque [Nm] |
|---------|----------------------|------------------------|
| 25 | 4 x M 12 | 10 |
| 32 | 4 x M 16 | 15 |
| 40 | 4 x M 16 | 20 |
| 50 | 4 x M 16 | 26 |
| 65 | 4 x M 16 | 40 |
| 80 | 8 x M 16 | 25 |

Pipe screws, DIN/ISO flanges drilled to ASME

| DN | | No. x size [ASME] | Tightening torque | |
|------|--------|-------------------|-------------------|----------|
| [mm] | [inch] | | [Nm] | [in-lbs] |
| 25 | 1" | 4 x 1/2" | 8 | 70 |
| 32 | 1 1/4" | 4 x 1/2" | 12 | 105 |
| 40 | 1 1/2" | 4 x 1/2" | 15 | 135 |
| 50 | 2" | 4 x 5/8" | 25 | 220 |
| 65 | 2 1/2" | 4 x 5/8" | 30 | 265 |
| 80 | 3" | 4 x 5/8" | 45 | 400 |

1.2 Type plate, dry-running, ATEX- and housing markings

The stainless steel type plate is firmly riveted to the housing:

If the operator attaches his identification, it must be ensured that the pump matches the application in question.

Example of type plate:

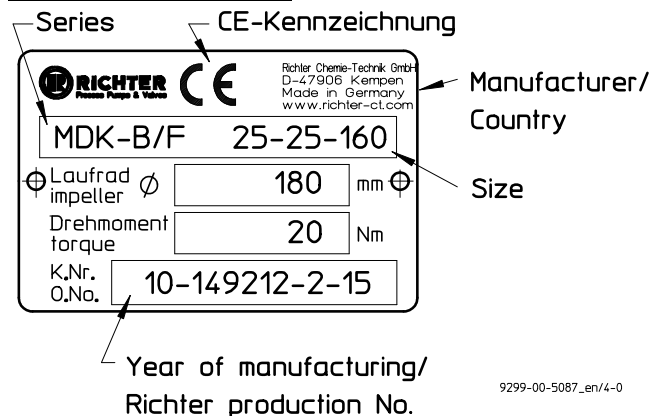

Dry-running:

Achtung! Kein Trockenlauf zulässig. Mindestdurchfluss muss gewährleistet sein.

Attention! No dry running. Minimum flow rate must be ensured.

9299-00-5087-0

ATEX marking:



Housing identification:

The following are visible on the housing according to DIN EN 19:

- ◆ Nominal size
- ◆ Rated pressure
- ◆ Housing material
- ◆ Manufacturer's identification
- ◆ Melt number/Foundry identification
- ◆ Cast date

1.3 Spare parts

Spare parts for two years of continuous operation in accordance with DIN 24296 and in consultation with the manufacturer.

2 Notes on safety

This operating manual contains fundamental information which is to be observed during installation, operation and maintenance.

It must be read before installation and commissioning!

This operating manual must always be available at the place of use of the machine/plant.

In addition to the general notes on safety under the main heading "Safety", special notes on safety are included at other points and must be observed.

Installation, operation and maintenance are to be performed by qualified staff.

The area of responsibility, authority and supervision of the staff must be exactly regulated by the customer.

If the staff does not have the necessary expertise, they are to be trained and instructed.

If necessary, this can be provided by the manufacturer/supplier on behalf of the machine operator.



General hazard symbol! People may be put at risk.



Safety symbol! The pump and its function may be put at risk if this safety symbol is not observed.



EU marking! Explosion-protected equipment must be identified for work in potentially explosive areas.



Warning of a magnetic field!



Warning of electric power!



This warning sign must be used if people with a pacemaker are at risk, e.g. from a strong magnetic field.

It is imperative to observe signs attached directly to the pump / unit, e.g.:

- ◆ Direction of rotation arrow
 - ◆ Warning against dry-running
- and they are to be kept legible.

Non-observance of the notes on safety may result in the loss of any and all claims for damages.

Non-observance may involve the following hazards:

- ◆ Failure of important functions of the machine/plant.
- ◆ Failure of electronic equipment and measuring instruments due to magnetic fields.
- ◆ Risk to people and their personal property from magnetic fields.
- ◆ Risk to people from electric, mechanical and chemical effects.
- ◆ Risks to the environment through leaks of hazardous substances.



If the unit is used in potentially explosive areas, special attention is to be paid to the sections identified with "Ex" in this operating manual.

2.1 Intended use

Richter pumps of the series MDK-B are plastic-lined magnetic drive centrifugal pumps for the leak-free conveyance of aggressive, toxic, pure and inflammable liquids.

The pump is equipped with a permanent magnetic synchronous drive.

For vertical installation of the pumps, please consult the manufacturer.



The observance of the specified physical limits is important for perfect functioning and safe operation, especially with regard to explosion protection to prevent potential sources of ignition (see [Section 2.6](#)):

- ◆ It must be ensured that the pump is always filled with liquid during operation.
- ◆ For safe pump operation, we recommend a flow rate which lies between 0.3 and 1.1 Q_{opt} . The maximum operating temperature must never be exceeded. See [Section 2.6.7](#). In case of doubt, you must consult the manufacturer.
- ◆ The manufacturer must be consulted in the event of entrainment of gas >2% as well as solids in order to avoid a lack of lubrication and dry-running.
- ◆ The plant NPSH value (NPSHA) should be 0.5 m higher than the NPSH value of the pump (NPSHR). See also [Section 5.4.1](#).



Inadmissible modes of operation, even for a short period, may result in serious damage to the unit.

In connection with explosion protection, potential sources of ignition (overheating, electrostatic and induced charges, mechanical and electric sparks) may result from these inadmissible modes of operation; their occurrence can only be prevented by adhering to the intended use.

Furthermore, reference is made in this connection to the Directive 95/C332/06 (ATEX 118a) which contains the minimum regulations for improving the occupational health and safety of the workers who may be at risk from an explosive atmosphere.



This unit must not be operated above the values specified in the data sheet as regards the fluid to be conveyed, flow rate, speed, density, delivery head and operating temperature as well as the motor rating.

The instructions contained in the operating manual or contract documentation must be observed; if necessary consult the manufacturer.

All important features are documented in the data sheet included in the scope of delivery.

In the event of operating conditions other than those described in the data sheet, the following are to be checked again:

- ◆ design of the pump
- ◆ design of the accessories
- ◆ resistance of the materials.

2.2 For the customer/operator

The following must be observed:

- ◆ The notes on safety contained in this operating manual,
- ◆ the prevailing regulations on accident prevention,
- ◆ in-house work, operating and safety regulations of the customer.
- ◆ Hot or cold machine parts must be protected by the customer against being touched.
- ◆ No protective facilities may be removed when the machine is in operation.
- ◆ Hazards due to electricity are to be excluded.
- ◆ Leaks of hazardous media (e.g. explosive, toxic, hot) must be removed so that no risk arises for people and the environment. The statutory provisions are to be observed.



Caution when using the units in potentially explosive area! Inadmissible modes of operation must be prevented.

2.3 For maintenance

In principle, work on the unit may only be performed when it is at a standstill.

It is imperative to observe the procedure for stopping the machine described in this operating manual. See [Section 6.3](#).

Pumps which convey media which are a health hazard must be decontaminated.

All safety and protective facilities must be remounted or enabled immediately after the end of work.

In the assemble state, if the safety notes (see also [Section 5.1 and 7.5.2](#)) are observed, the magnetic drives do not cause any risks or have any affect on the environment.



During dismantling and assembly as well as during transport and storage of the magnetic drives as single components, the notes on safety in [Section 7.5.2](#) must be observed.

The points listed in [Section 6.1](#) must be followed before recommissioning.

2.4 Conversion work and production of spare parts by the customer

Conversion of or changes to the machine are only admissible after consultation with the manufacturer.

Original spare parts and accessories authorised by the manufacturer serve to enhance safety.

The use of other parts may annul the liability for any resultant consequences.

2.5 Improper operation

The operational safety of the machine supplied is only guaranteed if it is used properly in accordance with [Section 2.1](#) of this operating manual.

The operating limits specified in the data sheet must under no circumstances be exceeded.

2.6 Special requirements for explosion protection

If the units are used in potentially explosive areas, the measures and notes in [Sections 2.6.1 to 2.6.9](#) are imperative to guarantee the explosion protection.

2.6.1 Filling the unit



During pump operation the wetted interior of the pump must always be filled with the liquid medium.

This prevents any explosive atmosphere and the risk of dry-running.



If the customer cannot ensure this, we recommend that appropriate monitoring facilities be provided.



All auxiliary, heating and cooling systems must also be carefully filled.

2.6.2 Special operating conditions



In the standard design the can chamber and the plain bearings are cooled and lubricated by a flushing flow.

Owing to properties of the medium (e.g. sticking due to inadmissible solids entrainment, clogging, gas entrainment etc.) the cooling flow can be interrupted and, as a result, an inadmissible temperature rise may occur. Provide appropriate monitoring facilities. See [Section 5.6](#).

If the flow rate is too high, the differential pressure upstream and downstream of the plain bearings could fall so much that a lack of lubrication or dry-running may occur.

If the flow rate is too low, the medium may heat up so much owing to the fluid friction that the max. admissible surface temperature of the relevant temperature class is exceeded.

Overloading, overheating, non-observance of the design data or the incorrect selection of the magnetic drive can lead to the decoupling of the inner and outer magnet assemblies. As a result, eddy currents may be induced on the inner and outer magnet assemblies and an inadmissible temperature rise may occur.

The situation is to be remedied by providing appropriate monitoring facilities. See [Section 5.6](#).

The plant NPSH value (NPSHA) should be 0.5 m higher than the NPSH value of the pump (NPSHR) to prevent a lack of lubrication or dry-running of the plain bearings.

2.6.3 Chargeable liquids



For operation with chargeable liquids with a conductivity $<10^{-8}$ S/m inert gas must be used for flushing during drain. See [Section](#)

[6.3](#).

2.6.4 Identification



The identification on the pump relates to the pump section. A separate declaration of conformity must be provided for the shaft coupling and motor and for other attachments as well as corresponding identification.

Example of the identification of the pump section:



I12GD IIC TX X.

For assembling the pump with components which are not explosion-protected (e.g. motor, shaft coupling), it is recommended to mask or remove the "potentially explosive" identification from the pump component and, if necessary, from other accessories.

In this case the declaration of conformity applies without ATEX identification.

At surface temperatures which depend primarily on operating conditions, DIN EN 13463-1 Chapter 9.3 allows no temperature class or temperature to be indicated.

The temperature class must be determined by the operator in accordance with [Section 2.6.7](#) "Temperature Limits".

2.6.5 Check of the direction of rotation



If there is also a risk of explosion during the installation phase, the check of the direction of rotation must under no circumstances be conducted by briefly switching on the unfilled pump in order to prevent an inadmissible rise in temperature at the plain bearings.



We recommend you to only perform a check of the direction of rotation with with filled pump and with a rotating field instrument. See also

[Section 6.1.2](#).

2.6.6 Mode of operation of the pump

The pump may only be started with the suction side shut-off element fully opened and the discharge side shut-off element slightly opened. Start-up against a closed check valve is also possible. The discharge side shut-off element is to be regulated to the operating design point directly after run-up.

See also [Section 5.4.1](#).

Operation with closed shut-off valves in the suction and/or discharge lines is not permitted!



There is a risk that even after a short time high surface temperatures on the pump housing may occur owing to rapid heating of the liquid in the pump interior.



A rapid rise in the pressure inside the pump involves the risk of overloading to the point of bursting.



The pump must not be in operation in the unfilled or partially filled state (dry running). This results in serious damage to the pump and additional risks to the environment can arise.



Dry-running cannot only occur with an insufficiently filled interior but also in the event of high gas contents in the liquid medium.

Operation of the pump outside the admissible operating range may also lead to dry-running (e.g. due to evaporation in the interior).

2.6.7 Temperature limits



In the normal operating condition the highest temperatures are to be expected on the surface of the pump housing.

In the case of liquids $>40^{\circ}$ C the surface temperature of the pump housing is generally lower than the temperature of the liquid as the lining has an insulating effect.



If the pump is heated (e.g. heating jacket), it must be ensured that the temperature classes prescribed in the annex are observed.

The not heated pump surface must have free contact with the environment.



During operation of the pump it must be ensured that excessive deposits of dust are prevented (regular cleaning) in order to prevent the pump surface from heating to above the admissible temperature.

The plant customer must ensure that the prescribed operating temperature is observed. The maximum admissible temperature of the liquid medium at the pump inlet depends on the temperature class and the selected lining material required in each case.

The following always applies: No inadmissible temperatures may be introduced into the motor and the specifications of the motor manufacturer must be observed.

The temperature limits of the fluid given in **Table 2** only apply when motors are used where the motor manufacturer permits at least the following temperatures for the motor flange and motor shaft:

Table 1

| Temperature class | Motor flange | Motor shaft |
|-------------------|--------------|-------------|
| T6 | 70 °C | 70 °C |
| T5 | 70 °C | 80 °C |
| T4 | 75 °C | 85 °C |
| T3 | 75 °C | 85 °C |
| T2 | 75 °C | 85 °C |
| T1 | 75 °C | 85 °C |

At the same time the specified max. admissible ambient temperature of 40 °C must not be exceeded.

Table 2 below indicates the admissible medium temperature, depending on the pump design, as a function of the temperature class in accordance with EN 13463-1.

Table 2

| Temperature class acc. to EN 13463-1 | Limit value of the temperature of the liquid |
|--------------------------------------|--|
| | PFA |
| T6 (85 °C) | 75 °C ¹⁾ |
| T5 (100 °C) | 90 °C ¹⁾ |
| T4 (135 °C) | 120 °C |
| T3 (200 °C) | 120 °C |
| T2 (300 °C) | 120 °C |
| T1 (450 °C) | 120 °C |

1) The limit values specified for the temperature of the medium at the pump inlet are determined for the most unfavourable case (high speed, low flow, low heat capacity of the medium, ...). Under favourable operating conditions the limit values specified may be increased by up to 5 K after consultation with the manufacturer.

In the case of motors with the type of protection "increased safety", no or low temperature entries are generally permitted for the motor shaft and motor flange related to an ambient temperature of 40 °C.

In these cases the max. admissible medium temperature is 20 K above the temperature which may be introduced into the motor.

e.g.: Max. motor shaft temperature: 60°C

Max. motor flange temperature: 65°C

This results in a maximum medium temperature for the pump of **80 °C (60 °C + 20K)**.

2.6.8 Maintenance



For safe and reliable operation, it must be ensured with regular inspection intervals that the unit is properly serviced and kept in a perfect technical condition.

In regard to media containing solids, the maintenance intervals must be set by the operator in accordance with the conditions of operation.

If auxiliary systems (e.g. cooling, heating) are installed, check to see whether monitoring facilities are required to ensure their function.

2.6.9 Electric peripheral equipment

Electric peripheral equipment, e.g. pressure, temperature and flow sensors etc. must comply with the prevailing safety requirements and explosion protection provisions.



Regular checks of the motor bearings in accordance with the operating manual of the motor manufacturer. Observe ATEX notes.

3 Transport and storage



The pump or the unit must be transported properly. It must be ensured that during transport the pump/unit remains in the horizontal position and does not slip out of the transport suspension points.

A pump or motor can be suspended from the crane lugs provided for this purpose.

The suspension points are not suitable for transporting a complete unit, i.e. pump with base plate and motor.

In this case, the slinging points for the ropes on the base plate are to be used. See **Fig.1**.

Exception:

The base plate 270 x 500 mm for the sizes 25-25-125 and 50-32-125 (group 1.1) has no rope slinging points. In this case the unit (pump, motor and base plate) is suspended from the crane lugs on the pump and motor.

The slinging ropes must not be attached to free shaft end.

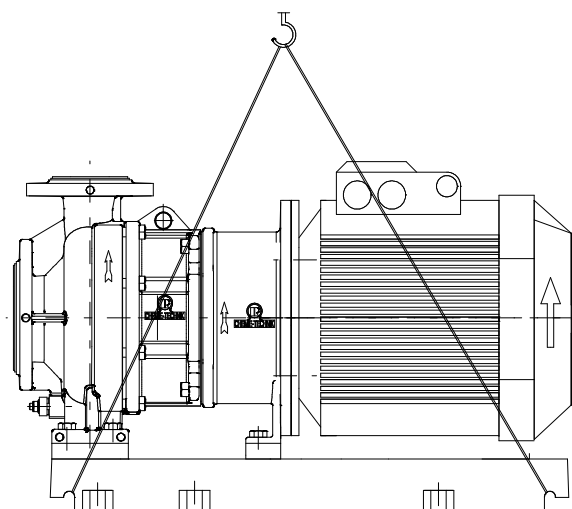

Fig. 1

Directly after receipt of the goods, the consignment must be checked for completeness and any in-transit damage.

Damaged pumps must not be installed in the plant.

Handle goods carefully to prevent damage.



When unpacking magnetic drives as single parts, the relevant notes in **Section 7.5.2** must be observed.

Flange covers serve as protection during transport and must not be removed.

If the unit is not installed immediately after delivery, it must be put into proper storage.

The product should be stored in a dry and vibration-free, well ventilated room at as constant a temperature as possible.

Elastomers are to be protected against UV light. In general, a storage period of 10 years should not be exceeded. An admissible storage period of 4 years applies to elastomers made of NBR.



If magnetic drives are stored as single parts, the relevant notes in **Section 7.5.2** are to be observed.

In the case of **prolonged storage** conservation agents on machined component surfaces and packing with a desiccant may be necessary.

3.1 Return consignments



Pumps which have conveyed aggressive or toxic media must be well flushed and cleaned before being returned to the manufacturer's works.

It is **imperative** to enclose a **safety information sheet / general safety certificate** on the field of application with the return consignment.

Pre-printed forms are enclosed with the installation and operating manual.

Safety precautions and decontamination methods are to be mentioned.

3.2 Disposal

Parts of the pump may be contaminated with medium which is detrimental to health and the environment and therefore cleaning is not sufficient.



Risk of personal injury or damage to the environment due to the medium or oil!

- ◆ Wear protective clothing when work is performed on the pump.
- ◆ Prior to the disposal of the pump:
 - Collect any medium, oil etc. which has escaped and dispose of it in accordance with the local regulations.
 - Neutralise any medium residues in the pump.
- ◆ Separate pump materials (plastics, metals etc.) and dispose of them in accordance with the local regulations

4 Product description

The housing dimensions, nominal ratings and technical requirements of the pump series MDK-B correspond to ISO 2858 / DIN EN 22858 / ISO 15783 / DIN ISO 5199. The technical requirements of the VDMA 24279 are satisfied.

The **sectional drawing** shows the design of the pump. See **Section 9**.

All components which come into contact with the medium are either plastic-lined or made of other resistant materials, e.g. silicon carbide.

The housing **100** consists of a metal armouring and a plastic lining.

The shaft spider with integral plastic thrust ring **338** is pressed into the housing and secured with the anti-torsion insert **566/1**.

Another design involves a two-piece shaft spider **338** with an inserted thrust ring **510/1** made of a hard material (SSiC).

The impeller assembly **237** contains the impeller and the wetted magnetic drive. The thrust ring **510/2** is pressed in on the suction side.

The two bearing bushes **545** are pressed in from the bearing pedestal side and secured with the anti-torsion insert **566/2**. The distance ring **504** is inserted in-between.

The can **159** is made of a stable non-metallic fibre composite material and a lining made of resistant plastic. The thrust ring **510/3** is pressed in and secured against turning on the shaft **222**. The shaft is secured against turning in the can.

The can is screwed with the lantern **344** against the housing. The intermediate ring **509/1** made of plastic ensures a uniform contact pressure.

The torque is transmitted from the motor shaft through whose key to the drive magnet assembly **858**.

This assembly is secured axially with the setscrew **904/1**. The magnets are glued into the drive magnet assembly and grouted with artificial resin.

Should the can become defective, the bearing pedestal gasket **404** seals the medium from escaping at least for a short time.

The **flushing flow** is guided on the outside past the impeller assembly into the can. The flushing flow returns to the housing through flushing bores in the impeller assembly and through the plain bearings.

Further design details are provided in the enclosed drawing. Additional information is also contained in the **brochure**.

5 Installation

5.1 Safety regulations



Equipment which is operated in potentially explosive areas must satisfy the explosion protection regulations.



People with a pacemaker are at risk from the strong magnetic field of the magnetic drive. It may be life-threatening for them to stay at a distance of less than 500 mm to the pump.

5.2 Installation of pump - unit

The structural work must be prepared in accordance with the dimensions in the installation drawing.

Method of installation: on a grouted base plate and firm foundation

- Align base plate on the ground foundation.
- Insert foundation bolts and grout base plate.
- Do not tighten the foundation bolts uniformly and firmly until the mortar has set.

Other possibilities of alignment are:

- ◆ 4-point-alignment
- ◆ 4-point-alignment with base plate.



As soon as additional equipment has to be mounted, the stability must be checked if the entire unit is to be installed without a foundation.

5.3 Alignment of pump - motor



The following information is of a general nature. If necessary, special notes of the motor manufacturer are to be observed.

- Prior to alignment work, loosen the screws **901/6**, **920/3** in the adapter. Align the unit with the housing so that there is no tension and retighten the screws.
- Use supports in the direct vicinity of the bolts foundation/base plate.

5.4 Piping

Before the pump is installed, both the suction and supply lines as well as the discharge line are to be cleaned.

Dirt or damage to the sealing surfaces is best avoided if the flange covers remain on the flanges until just before installation.

Use flange gaskets suitable for the medium.

The screw tightening torques in **Section 1.1** are to be observed for tightening the flange screws.

5.4.1 Nominal size

The operating design point of a centrifugal pump lies at the intersection of the pump curve and the pipe curve, see **Fig. 2**. The pump curve is provided by the pump manufacturer. The pipe curve is determined using diagrams or PC programs.

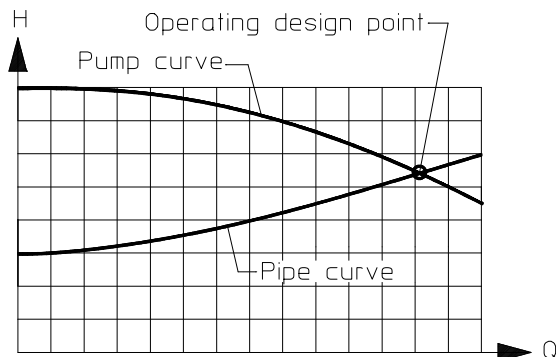

9299-00-5009_en/4-0

Fig. 1

Under no circumstances can the nominal size of the piping be derived from the connected nominal size of the pump.

The pipe nominal size can also be determined using the flow rate as a rough guide.

$$v \text{ (m/s)} = \frac{Q \text{ (m}^3\text{/s)}}{A \text{ (m}^2\text{)}}$$

The velocity in the suction line should not exceed 2.0 m/s and 5.0 m/s in the discharge line.

When determining the suction line nominal size, the NPSH value (net positive suction head) must also be observed. The **NPSHR value** required for the pump is specified in the data sheet.



The NPSHA available in the plant should be at least 0.5 m higher than the NPSHR required for the pump. Otherwise, this will lead to a drop in the delivery head, cavitation or even failure of the pump.

5.4.2 Nozzle loads

The pump can be subjected to nozzle loads in accordance with ISO 5199.

Changes in the length of the piping caused by temperature are to be allowed for by appropriate measures, e.g. the installation of expansion joints.

5.4.3 Suction line

The suction lines must always be laid on a rising gradient towards the pump. Otherwise, gas bubbles may form which considerably reduce the suction line cross section. Eccentric transition elements must be installed between different pipe diameters.

Valves which disrupt the course of flow should not be installed directly upstream of the pump.

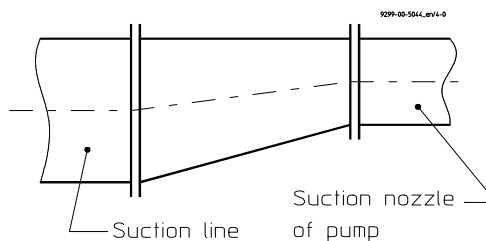

Fig. 3

5.4.4 Supply lines

Supply lines should vent towards the reservoir and are therefore to be laid with a constant downward gradient towards the pump. Should the pipe fittings upstream of the pump be horizontal, a low point can, of course, be located upstream of these internals. From here the pipe is then laid with an upward gradient to the pump so that the gas bubbles which form here can escape through the pump. Valves which disrupt the course of flow should not be installed directly upstream of the pump.

5.4.5 Discharge line

Do not arrange the shut-off valve directly above the pump but initially provide a transition section.

The discharge nozzle velocity of the medium can – if necessary – be reduced.

5.4.6 Venting and draining

Venting can take place into the discharge line or upstream of the discharge valve.

A venting line can also be used as a bypass, drain or flushing line.

The pump housing is fitted with a drain connection as a standard feature. Optionally, the drain bore can be enlarged. See **Figure 4**.

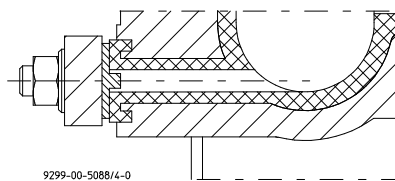

Fig. 4

5.5 Pipe fittings

The following pipe fittings are available from Richter on request:

- ◆ Shut-off valves
- ◆ Check valves
- ◆ Sight glasses
- ◆ Priming vessels
- ◆ Strainers
- ◆ Pressure gauges

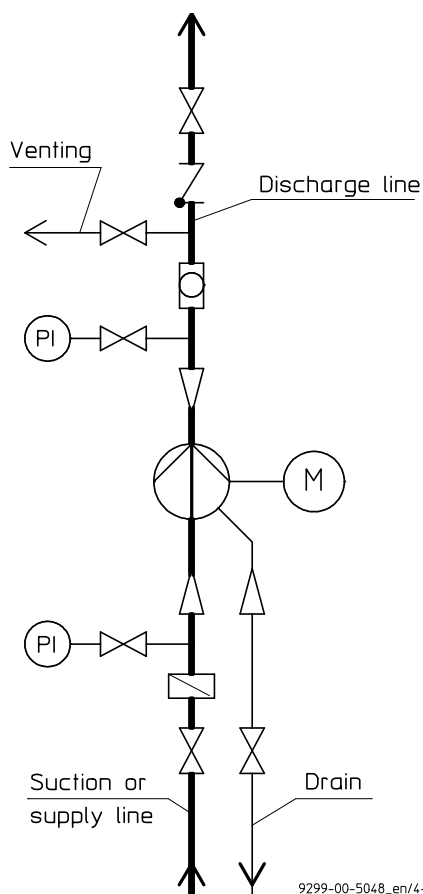

Fig. 5

5.6 Monitoring facilities



Appropriate monitoring facilities are to be recommended, depending on the requirements placed on operational safety and availability of the unit.

Richter provides information on request and can supply:

- ◆ Flow meters
- ◆ Filling level indicators
- ◆ Motor load monitors

You can obtain the publications "Safe Operation of Centrifugal Pumps" and "The Operation of Centrifugal Pumps without NPSH Problems" on request.

5.7 Drive

The power consumption of the pump at the operating design point is specified in the data sheet and works certificate. If the operating design point was not known when the pump was dispatched, the power consumption can be read off the appropriate performance curves. The max. density, the max. viscosity and a safety margin are to be allowed for.

Care must be taken when selecting the motor size to ensure that the excess power is not too great. During start-up the magnetic drive could otherwise stop.

The magnetic drive rating at the nominal speed of 2900 rpm is given in the pump data sheet.

If the motor rating exceeds this magnetic drive rating – at nominal speed –, it is necessary to check for any stoppage of the magnetic drive.

This also applies if the required drive rating exceeds 80% of the magnetic drive rating – at nominal speed. Consult Richter if necessary.

Different operating data can be achieved without changing the pump through the use of different speeds, e.g. by means of a frequency converter.

The pump with base plate and motor is illustrated in the **installation drawing**.

The **operating manual of the motor manufacturer** must be observed.



A motor with a valid ATEX certificate is to be used if employed in zone 1 and 2.

5.8 Electric connection

The operator is obligated to connect the assembly in accordance with existing regulations 8 (IEC, VDE, etc.).



Allow only a trained electrician to perform the electrical connection.

Compare the existing mains voltage with the indications on the motor's manufacturer's nameplate and choose a suitable circuit.

A motor protection device (motor-circuit switch) is urgently recommended.



Danger of explosion if the electrical installation is incorrect.



In areas at risk of explosion, IEC 60079-14 must also be observed for the electrical installation.

If the pump is mounted on a base plate, ensuring electrical conduction through the use of a chopper disk or contact disk on the housing foot and support bracket.

The assembly must be grounded in accordance with currently effective regulations, for example, on the base plate.

6 Commissioning/Shutdown

6.1 Initial commissioning

If the pump has been test-run with water: Unless special agreements have been reached, there may still be some residual amounts of water in the pump. This must be noted in view of a possible reaction with the medium.

6.1.1 Filling the pump housing

- Check to see whether the screws on the suction flange, discharge flange, housing flange and drain flange are tightened. For screw tightening torques see **Section 1.1**.
- Open the suction line fully so that the medium can flow into the pump.
- Open the discharge valve so that the air in the pump can escape.
- If air cannot be vented into the discharge line, e.g. a drop in pressure in this line is not permitted, venting must be performed upstream of the discharge valve.
- Monitor the venting operation until no air but only liquid emerges.
- Close the discharge valve again until only the minimum flow rate is obtained after the motor has been started. 

6.1.2 Start-up

- Check the direction of rotation of the motor with a rotary field instrument. 
- As viewed from the motor, the direction of rotation of the pump is clockwise. See also the **direction of rotation arrow** of the pump.



If no rotating field instrument is available, the motor may also be activated briefly, with the pump filled, so that it does run up. You can observe the direction of rotation through the fan hood.



The pump must not run dry during the check of the direction of rotation. The pump must be completely filled with liquid. The maximum admissible flow rate must not be exceeded.



Otherwise the plain bearings can run dry in both cases.

- Switch the motor on.
- Set the desired flow by opening the discharge valve.



When the motor is running but the pump is not conveying, this means that the magnetic drive has stopped.

Switch the motor off immediately to prevent overheating of the magnet assemblies.

Then proceeded as follows:

- Close discharge valve down to the position "minimum flow rate".
- Start motor again.

If the magnetic drive stops again, look for the cause.

6.2 Operating limits



The operating limits of the pump/unit in terms of pressure, temperature, power and speed are entered in the data sheet and it is imperative to observe them!

6.2.1 Abrasive media



If liquids with abrasive constituents are conveyed, increased wear at the pump is to be expected. The inspection intervals should be reduced compared with the usual times.

6.2.2 Min./max. flow rate

The operating range generally recommended lies at $0.3 Q_{opt}$ to $1.1 Q_{opt}$. Consult the manufacturer for operation outside this range and observe **Section 2.6.2**.

6.3 Shutdown

- Close discharge valve down to the position "minimum flow rate".
- Switch motor off.
- Close discharge valve completely.

Only close the suction line if the pump is to be drained or dismantled.



For all work on the machine, make sure that the motor cannot be inadvertently switched on.



If the pump is to be evacuated or flushed, observe the local regulations.



If the pump has been operated with a chargeable liquid, it must be filled with inert gas (e.g. nitrogen) to prevent an explosive atmosphere.

It is recommended to wait one hour before the pump is dismantled from the plant to permit static peak charges to be eliminated.

If the pump is returned to the manufacturer's, clean the pump very thoroughly.

See also **Section 3.1**.

6.4 Restarting

When the pump is restarted, it must be ensured that all the relative steps as described in **Section 6.1** are repeated, depending on the progress of the shutdown operation.

6.5 Improper operations and their consequences (examples)



Inadmissible modes of operation, even for a short time, can result in serious damage to the unit.

In connection with explosion protection, potential sources of ignition (overheating, electrostatic and induced charges, mechanical and electric sparks) may result from these inadmissible modes of operation; their occurrence can only be prevented by adhering to the intended use.

Pump is started up without medium :

- ◆ The plain bearings in the pump may be destroyed.
- ◆ Other pump components may be destroyed due to overheating.

Operation with magnetic drive stopped :

- ◆ If no heat is dissipated, damage to the inner and drive magnet assemblies may occur.

Suction line not opened or not opened fully :

- ◆ Pump is cavitating – material damage to pump and plain bearings
- ◆ Pump does not attain the required delivery head or flow rate.
 - ◆ Pump may be destroyed due to overheating.

Discharge valve closed too much :

- ◆ Pump may be destroyed due to overheating.
- ◆ Axial thrust too great.

Discharge valve opened too much :

- ◆ Pump can cavitate. Particularly severe with an empty discharge line.
- ◆ Risk of pressure surge.
- ◆ Possible damage to the plain bearings.
- ◆ Magnetic drive may stop.
- ◆ Motor may be overloaded.

Suction valve and discharge valve closed :

- ◆ Destruction due to rapid overheating and sharp rise in pressure.

Control of the pump with the suction valve :

- ◆ Cavitation – the volume may only be regulated on the discharge side.

Overrun of the admissible gas content:

- ◆ The flow may stop.
- ◆ Switch pump and vent off for renewed conveyance.
- ◆ Make sure that the gas content is not exceeded, as described in the intended use.

7 Maintenance

7.1 Screw connections of the housing

After initial loading by the operating pressure and operating temperature the tightening torques of all connection screws must be checked at the following points:

- ◆ housing flange
- ◆ suction flange
- ◆ discharge flange
- ◆ draining flange

See also **Section 6.1.1, para. 1.**

Other inspections are to be performed regularly, depending on the operating requirements.

7.2 Motor

The operating manual of the motor manufacturer must be observed.



A motor with a valid ATEX certificate is to be used if employed in zone 1 and 2.

Observe the ATEX notes of the motor manufacturer.

7.3 Cleaning

Care must be taken when cleaning the pump to ensure that it is not exposed to a strong water jet.

7.4 Stand-by pumps

If a pump is on stand-by, it is to be started up from time to time.

This operation is to be performed more often for pumps which are exposed to very strong vibrations from the plant.

When dismantling the pump from the plant, drain it, thoroughly clean it, seal with flange covers and store in accordance with the instructions.

7.5 Notes on dismantling

- ◆ All repair and maintenance work is to be performed by skilled staff using appropriate tools and original spare parts.
- ◆ Is the necessary documentation available?
- ◆ Has the pump been taken out of operation, evacuated and flushed correctly? See also [Section 6.3](#).
- ◆ If no new assembly is performed immediately after dismantling, the plastic and ceramic components in particular must be stored carefully.

7.5.1 Protective clothing



Even if the pump has been properly evacuated and flushed, residue of the medium may still remain in the pump, e.g. between sealing surfaces or in the bearing seats or in the can.

Plastic components may absorb medium which gradually emerges from the material after flushing.



Proper protective clothing is to be worn.

Protective clothing is also to be worn even if only the adapter is to be removed. Medium may penetrate the lantern chamber through the can.

7.5.2 Magnetic fields



Caution ! Strong magnetic fields

Risk during dismantling and in the vicinity of magnetic drives as single parts.

Remove loose parts and other magnetisable metals from the work bench. They could otherwise be attracted: Risk of accident!

Place any tools needed at a safe distance.

Keep electronic equipment and measuring instruments at a distance. In cases of doubt consult the equipment manufacturer.

Hold magnetic drives as single parts firmly or secure. Otherwise they could be attracted, for example, by a vice: Risk of accident!



People with an artificial pacemaker
Keep torso at a minimum distance of 500 mm.

As a safety precaution, a distance of 150 mm should be observed for watches, electric data carriers, data carriers with a magnetic strip etc.

7.5.3 Changing the motor

If the motor has to be changed, the pressure-bearing section of the pump can remain in the plant.

For procedure, see [Section 7.6.2](#).

7.6 Dismantling

There are two possibilities for dismantling:

1. Dismantling the complete pump from the plant.
2. Dismantling the complete slide-in-unit with motor as the pump housing can remain in the plant connected to the piping.

Dismantling of the complete pump is described here.

7.6.1 Removal of motor, adapter and drive magnet assembly

- Undo screws **901/5** and nuts **920/5** from the lantern / adapter.
- Undo adapter **346** using 2 levers from the centering of the lantern **344**.
- Pull motor with adapter and drive magnet assembly out of the lantern.



Caution! Magnetic forces!
Risk of accident !

Axial forces are produced when the plain bearing pedestal is pulled out of the bearing pedestal. These forces diminish again abruptly after it has been removed.

The operating torque of the magnetic coupling installed is specified on the **type plate**.

7.6.2 Dismantling motor, adapter and drive magnet assembly

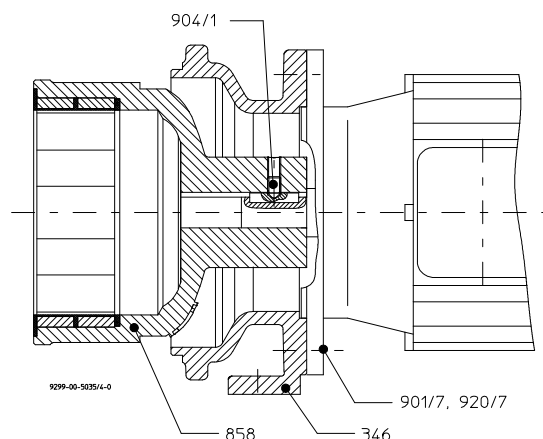

Fig. 6

- Undo motor nuts and screws **901/7**, **920/7**.
- Pull adapter **346** forward.
- Undo setscrew **904/1**.
- Pull drive magnet assembly **858** off the motor shaft using a pulling-off device.
- Remove adapter.
- See **Fig. 6**.



Caution! Magnetic forces.

7.6.3 Dismantling slide-in unit

- Undo housing screws **901/3**.
- Remove lantern **344** with bearing pedestal gasket **404**.
- Pull can **159** with intermediate ring **509/1** up and out. While doing so, the shaft **222** and impeller assembly **237** are also removed.
- Remove housing gasket **401**.
- Pull impeller assembly **237** off the shaft **222**.
- Remove shaft **222** with thrust ring **510/3** from the can. Place a suitable tool, e.g. scribing iron, behind the thrust ring and pull it off applying force at several positions.
- Remove thrust ring **510/2** using a screwdriver. Apply two screwdrivers alternately to the grooves in the impeller assembly **237** and carefully turn.
- Press out the bearing bushes **545** and distance ring **504** from the suction side of the impeller. Use a suitable mandrel made of plastic.
- Remove anti-torsion insert **566/2**.

7.6.4 Dismantling housing/shaft spider

- Press shaft spider **338** out of the housing from the suction nozzle side. Use a suitable pipe made of plastic.
- Remove anti-torsion insert **566/1**.
- With the design "shaft spider with thrust ring" the thrust ring **510/1** is pressed into the shaft spider and cannot be removed. If necessary, it must be replaced together with the shaft spider.
- Dismantling can be checked using the sectional drawing in **Section 9.2** and the components available.

7.7 Notes on assembly

- ◆ Use original spare parts. See also **Section 2.4**.
- ◆ Do not use defective parts.
- ◆ Apply Anti-Seize special assembly paste (e.g. from Weicon) to the fitting surfaces (not of stainless steel parts) and screw thread prior to assembly.

- ◆ Install plain bearings in pairs as supplied or stored.
- ◆ Check whether all parts fit and then assemble them.
- ◆ Important dimensions (centerings, bearing seats, or bearing clearances) are to be checked prior to assembly, e.g. by fitting parts together as a test
- ◆ It is recommended to replace the housing gasket **401** during assembly.
- ◆ Many metallic particles adhering to magnetic components such as the impeller assembly **237** and drive magnet assembly **858** must be removed prior to assembly. For this purpose simple plasticene can be used..
- ◆ A complete assembly process is described in the following.
Sub-sections can be deduced from this.
- ◆ See also **Section 7.5**.

The following assembly dimensions must be observed:

| | Dimension F [mm] | |
|------------------|------------------|------|
| | min. | max. |
| Group 1.1 | 87 | 87.7 |
| Group 1.2 | 86.5 | 87.2 |
| Group 1.3 | 87.5 | 88.2 |

Groups see **Section 1**.

Dimension F :

End face of drive magnet assembly to contact surface of adapter. See **Fig. 7**

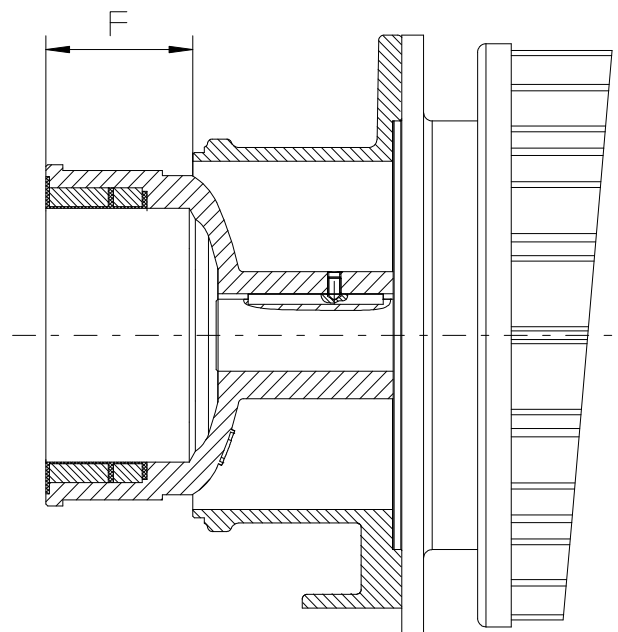

9299-00-5029/4-0

Fig.7

7.7.1 Table for target dimension Z

| Size | Dimension Z [mm] |
|-----------|------------------|
| 25-25-125 | 1.35 - 2.8 |
| 50-32-125 | 1.35 - 2.8 |
| 25-25-160 | 1.35 - 2.8 |
| 50-32-160 | 1.35 - 2.8 |
| 80-50-160 | 1.35 - 2.8 |
| 50-32-200 | 1.35 - 2.8 |
| 65-40-200 | 1.35 - 2.8 |
| 80-50-200 | 1.35 - 2.8 |

Z : axial play required.

The impeller assembly must, for example, have a minimum axial play after assembly. This **axial play Z** can be checked after assembly against the drawing **Fig.8**.

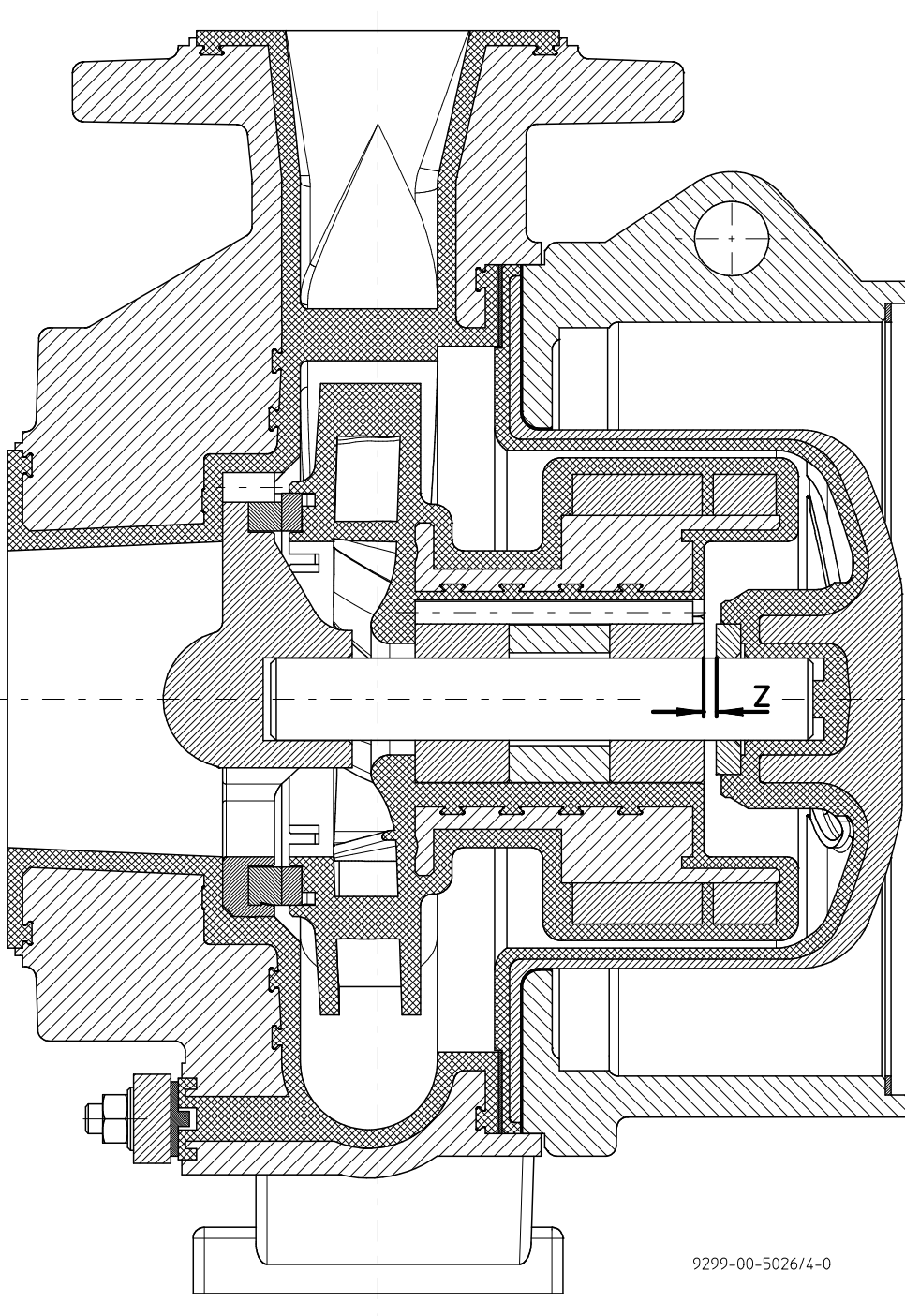

9299-00-5026/4-0

Fig.8

7.8 Assembly

A complete assembly process is described in the following.

Sub-sections can be deduced from this.

7.8.1 Assembly of housing / shaft spider

- Introduce anti-torsion insert **566/1** into shaft spider **338**.
- Press shaft spider into the housing using a hand press. Use an appropriate pipe made of plastic
- There are two designs of the shaft spider:
 1. Shaft spider **338** with integral thrust ring.
 2. Two-piece shaft spider **338** with inserted thrust ring **510/1**.
- Make sure that in the case of the two-part shaft spider the thrust ring points with the lubricating grooves towards the impeller.
- Press in until engagement can be felt.

7.8.2 Assembly of slide-in unit

- Align anti-torsion grooves of the thrust ring **510/2** exactly with the guides of the impeller assembly.
- Carefully press thrust ring **510/2** right into the impeller assembly **237**. When doing so, use a soft intermediate shim.
- Check whether the thrust ring protrudes about 2 mm out of the impeller assembly. See **Fig. 9**.

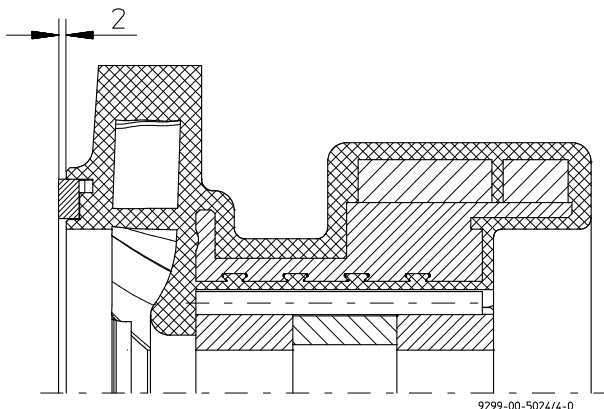

Fig. 9

- Press in bearing bush **545/1** on the suction side together with the anti-torsion insert **566/2**.
- Insert distance ring **504**.
- Press in bearing bush **545/2** on the bearing pedestal side.
- Push thrust ring **510/3** onto the shaft **222**. Make sure that the flushing grooves are in the direction of the housing.
- Press shaft **222** into the can **159**. Pay attention to the anti-torsion surfaces.

Push intermediate ring **509/1** onto the can.

See **Fig. 10**.

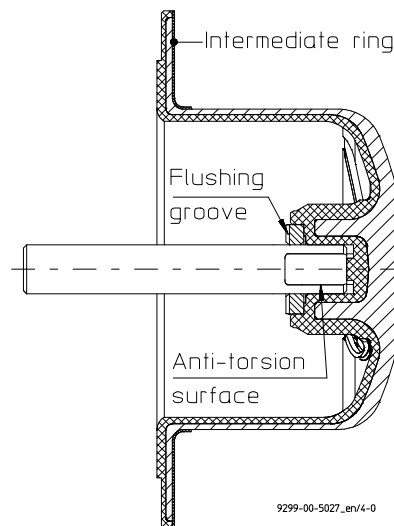

Fig. 10

7.8.3 Final assembly

- Secure the housing with the suction nozzle on a work bench or worktop. Protect the plastic working strip against damage with a suitable support.
- Insert housing gasket **401** into the housing centering.
- Place entire impeller assembly **227** concentrically onto the shaft spider **338**.
- Mount complete can with shaft **222**.
- Insert can unit with shaft into the impeller assembly and shaft spider.
- Attach lantern **344**. For tightening torques for the housing screws **901/3**, see **Section 1.1**.
- Check whether the impeller assembly has axial play. When doing so, reach through the suction or discharge nozzle and move the impeller assembly axially. See **Section 7.7.1**.
- Screw adapter **346** loosely onto motor **800/1**.
- Push drive magnet assembly **858** onto the motor shaft.
Make sure that the drive magnet assembly is pushed completely onto the motor shaft.
- Undo adapter and push forwards.
- Drill the key of the motor shaft for setscrew **904/1**.
- Screw on the setscrew **904/1** and secure with Loctite 243.
- Screw adapter tight to motor.
- Insert bearing pedestal gasket **404** into lantern **344**.
- Push drive magnet assembly into the lantern.



Strong axial forces occur during this operation.

- Tighten lantern screws and nuts **901/5**, **920/5** slightly
- Align housing support bracket with the adapter support bracket.
- Screw lantern nuts and screws **901/5**, **920/5** tight.

7.9 Tests

On request the pumps are tested with water at the manufacturer's.

The operating data measured are then documented in a **works certificate**.

If, during a test after repairs, discrepancies compared with the works certificate are discovered, the following people can be called in:

- 1) in-house pump office
- 2) The manufacturer Richter or its local agent.

The following conveying data can be checked using the **pump performance curves**:

- ◆ Flow rate
- ◆ Head
- ◆ Power requirement
- ◆ NPSHR

8 Faults



Faults may result from inadmissible modes of operation. Such inadmissible modes of operation – even brief ones – may cause serious damage to the unit.

In connection with explosion protection, potential sources of ignition (overheating, electrostatic and induced charges, mechanical and electric sparks) can result from these inadmissible modes of operation; their occurrence can only be prevented by adhering to the intended use.

See also **Section 6.5**.

Should there be any uncertainty about the remedy to be applied, please inquire at the in-house pump office or at the pump manufacturer's.

No delivery :

- ◆ Is the pump filled and vented?
- ◆ Is the suction line open, vented, cleaned and correctly laid?
- ◆ Is the discharge line open, vented, cleaned and correctly laid?
- ◆ Is the geodetic head too high?
- ◆ Is air being drawn in?
- ◆ Has the magnetic drive stopped?

Flow rate too low :

- ◆ Have the pump, suction line and discharge line been completely vented, filled and cleaned?
- ◆ Have any strainers installed been cleaned?
- ◆ Are all shut-off devices open?
- ◆ Is the geodetic head too high?
- ◆ Is the NPSHA too low or the NPSHR too high?
- ◆ Are the pipe resistances too high?
- ◆ Is the viscosity too high?
- ◆ Is the direction of rotation correct?
- ◆ Is the speed too low or the impeller diameter too small?
- ◆ Are pump parts worn?
- ◆ Gas in the medium?

Flow rate too high :

- ◆ Is the geodetic head too low?
- ◆ Are the pipe or nozzle resistances too low?
- ◆ Is the pump speed too high or the impeller diameter too large?

Delivery pressure too high :

- ◆ Is the speed too high or the impeller diameter too large?
- ◆ Is the density too high?

Motor consumes too much electricity :

- ◆ Is the flow rate, density or viscosity too high?
- ◆ Is the speed too high or the impeller diameter too large?

Pump does not run smoothly or creates noise :

- ◆ Are the ball bearings on the motor damaged?
- ◆ Are parts of the hydraulics damaged?
- ◆ Is the flow rate too low or too high?
- ◆ Is the impeller balanced?
- ◆ Is the pump twisted?
- ◆ Is there foreign matter in the pump?

Leak from the pump :

- ◆ Are all screws tightened to the correct tightening torque?
- ◆ Were the sealing surfaces assembled in a clean state?
- ◆ Have approved gaskets been installed?

9 Sectional drawing

9.1 MDK-B (close-coupled design)

| | | | |
|--------------|-------------------------|--------------|-----------------------|
| 100 | housing | 509/1 | intermediate ring |
| 122 | blind cover | 510/x | thrust ring |
| 159 | can | 545/x | bearing bush |
| 222 | shaft | 554/x | washer |
| 237 | impeller assembly | 566/x | anti-torsion insert |
| 338 | shaft spider | 800/1 | motor |
| 344 | lantern | 858 | drive magnet assembly |
| 346 | adapter | 901/x | hex. screw |
| 401 | housing gasket | 902/1 | stud screw |
| 404 | bearing pedestal gasket | 904/1 | setscrew |
| 415/1 | centering gasket | 920/x | hex. nut |
| 504 | distance ring | | |

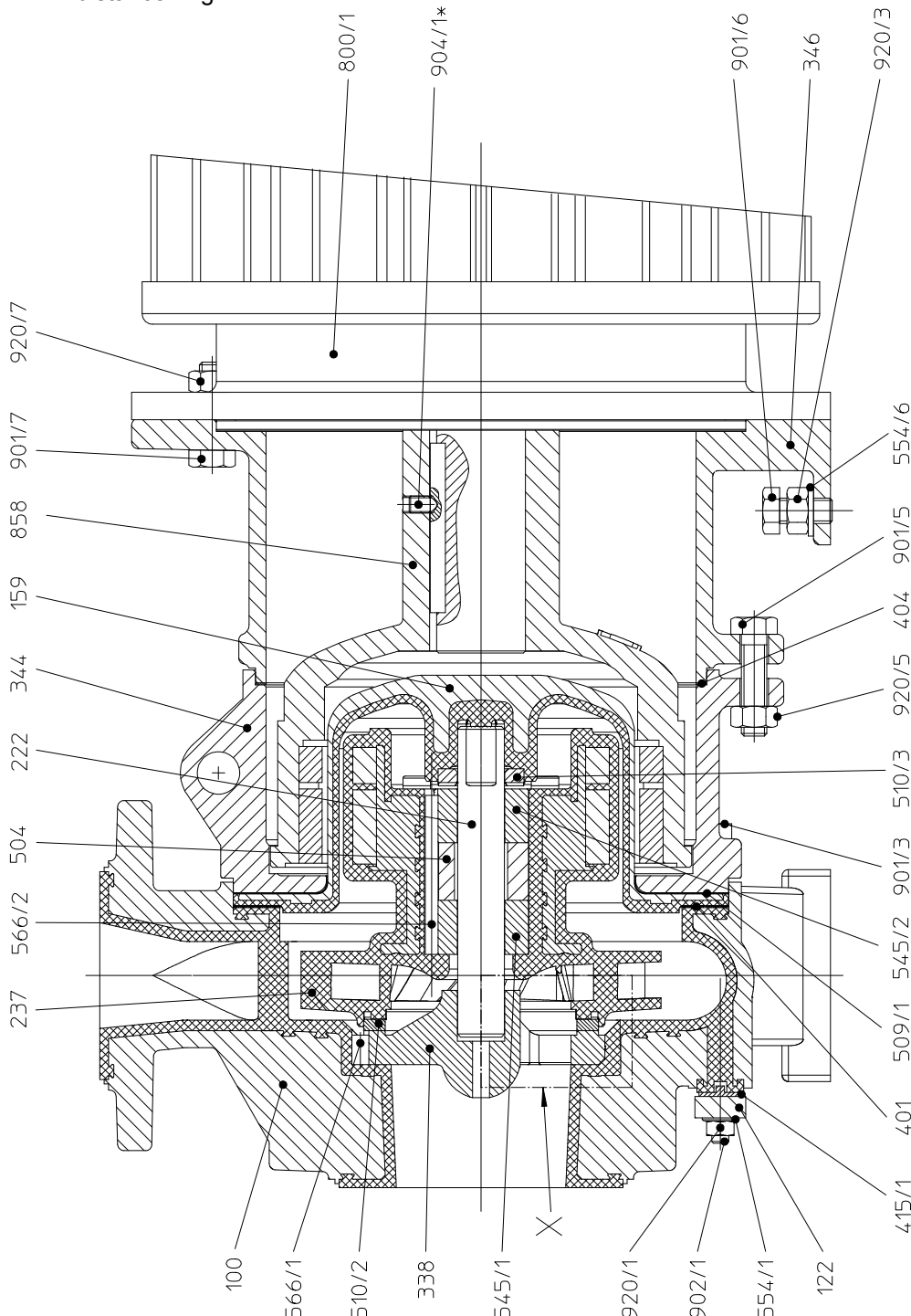

Detail X

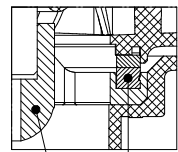

Option shaft spider with thrust ring

* Drill key of the motor shaft during assembly and secure setscrew 904/1 with Loctite 243

9299-00-5085_en14-0

Baureihe/Series/Série Ausführung **Magnetkupplungspumpe**
 Design **Magnet drive pump**
 Construction **Pompe à entraînement magnétique**



MDK
MDK-B

Modification techniques possibles sans réservations!
 Graphique non à l'échelle!
 Dimensions variables uniquement revêtues d'une signature!
 This leaflet is subject to alteration!
 Drawing not to scale!
 Certified for construction purposes only when signed!
 Technische Änderungen vorbehalten!
 Nicht maßstäblich!
 Maße nur mit Unterschrift verbindlich!

Einsatzgrenzen / operating limits

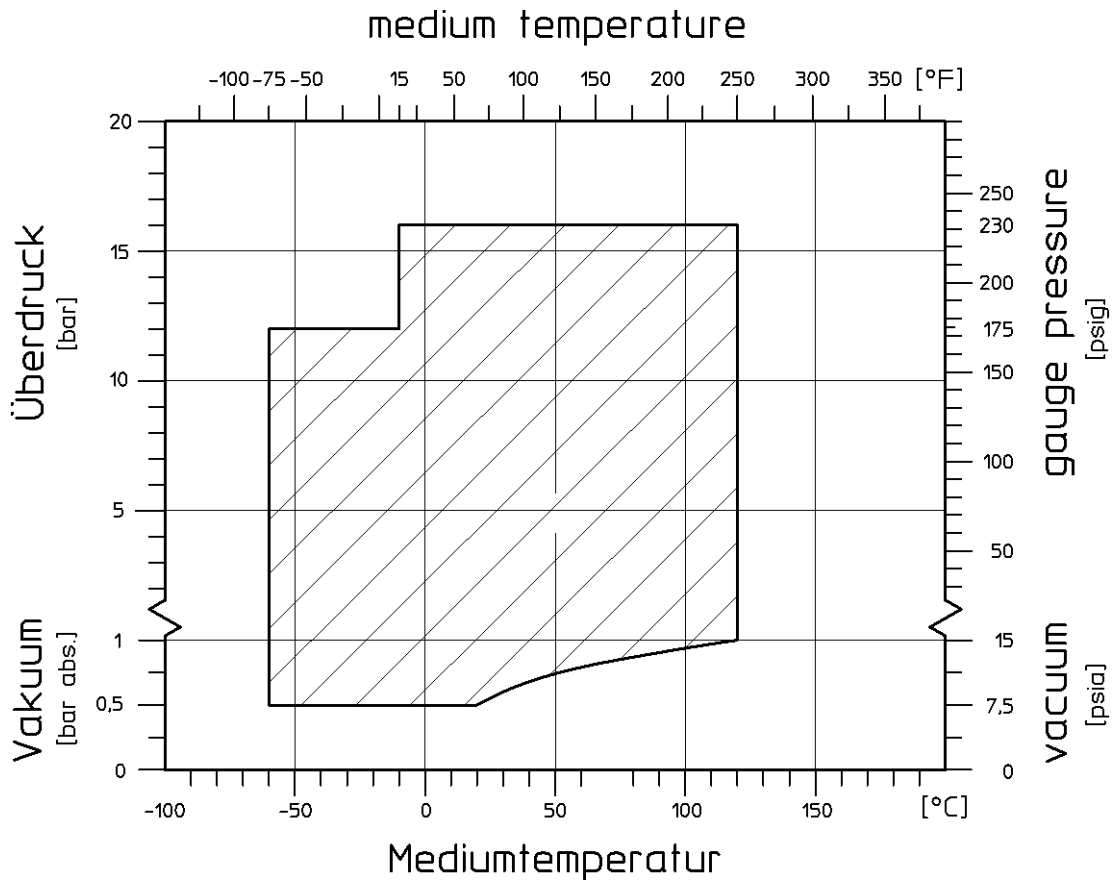

Bemerkung / remark :

Bei Einsatz unter ASME-Bedingungen (Sphäroguss nach A395) kann der Standardbereich auf -30°C und 16bar erweitert werden.

Application under ASME-specification (ductil iron acc. To A395) the standard range can be expanded up to 30°C and 16bar.

CE Konformitätserklärung nach EN ISO//IEC 17050
Declaration of Conformity according to EN ISO//IEC 17050

Produkt Magnetkupplungs-Chemiekreiselpumpe
 freies Wellenende, Blockausführung oder als Aggregat¹⁾
 Product *Magnetic Drive Chemical Centrifugal Pump*
Bare shaft, block version or as unit¹⁾

Baureihe MNK, MNK-B, MNK-X, MNK-XB, MNK-S, MNK-SB, MNKA, MNKA-B
 Series MPB, MDK, MDK-B, RMA, RMA-B, RMI, RMI-B

EU-Richtlinien 2006/42/EG Maschinenrichtlinie *Machinery Directive*
 EU-Directive 94/9/EG Explosionsschutzrichtlinie ATEX *Equipment explosive atmosphere*

Modul Interne Fertigungskontrolle
Production Quality Assurance

Angewandte EN 14121
 harmonisierte Normen EN 809
 Applied harmonised EN 13463-1
 Standards

Kennzeichnung 2006/42/EG
 Marking 94/9/EG



Die technische Dokumentation nach Richtlinie 94/9EG ist bei der u.a. benannten Stelle hinterlegt.
The technical documentation is filed by below mentioned notified body according to directive 94/9/EC.
 Physikalische-Technische Bundesanstalt (PTB), D-38116 Braunschweig

| Baureihe Series | Registrier-Nr. Registered # | Baureihe Series | Registrier-Nr. Registered # | Baureihe Series | Registrier-Nr. Registered # |
|--------------------|--------------------------------|--------------------|--------------------------------|--------------------|--------------------------------|
| MNK | 02ATEXD032 | MNKA | 04ATEXD007 | RMA | 09ATEXD062 |
| MNK-B | 03ATEXD006 | MNKA-B | | RMA-B | 09ATEXD062 |
| MNK-X | 02ATEXD032 | MPB | 03ATEXD068 | RMI | |
| MNKXB | 03ATEXD006 | MDK | 02ATEXD009 | RMI-B | |
| MNK-S | 02ATEXD032 | MDK-B | 03ATEXD008 | | |
| MNK-SB | 03ATEXD006 | | | | |

Das Unternehmen Richter Chemie-Technik GmbH bescheinigt hiermit, dass die o.a. Baureihen die grundsätzlichen Anforderungen der aufgeführten Richtlinien und Normen erfüllt.
Richter Chemie-Technik GmbH confirms that the basic requirements of the above specified directives and standards have been fulfilled.

Bevollmächtigt für die Zusammenstellung der technischen Unterlagen nach 2006/42/EG: A. Linges
Authorised person compiled the technical files according to 2006/42/EG:

1) Gilt nicht für das Aggregat nach 94/9/EG (ATEX Leitfaden Juni 2009 Abschn. 3.7.5 2.a)
 1) *Not valid for the unit according to 94/9/EG (ATEX Guideline June 2009 Paragraph 3.7.5 2.a)*

Kempen, 01.03.2010



G. Kleining
 Leiter Forschung & Entwicklung
 Manager Research & Development



A. Linges
 Leiter Qualitätsmanagement
 Quality Manager

 **Konformitätserklärung** nach EN ISO//IEC 17050
Declaration of Conformity according to EN ISO//IEC 17050

| | |
|---|---|
| Produkt <i>Product</i> | Magnetkupplungs-Chemiekreiselpumpe als Aggregat <i>Magnetic Drive Chemical Centrifugal Pump as unit</i> |
| Baureihe <i>Series</i> | MNK, MNK-B, MNK-X, MNK-XB, MNK-S, MNK-SB, MNKA, MNKA-B MPB, MDK, MDK-B, RMA, RMA-B, RMI, RMI-B |
| EU-Richtlinien <i>EU-Directive</i> | 2006/42/EG Maschinenrichtlinie <i>Machinery Directive</i> |
| Modul | Interne Fertigungskontrolle <i>Production Quality Assurance</i> |
| Angewandte harmonisierte Normen <i>Applied harmonised Standards</i> | EN 14121 EN 809 |
| Kennzeichnung <i>Marking</i> | 2006/42/EG  |

Das Unternehmen Richter Chemie-Technik GmbH bescheinigt hiermit, dass die o.a. Baureihen die grundsätzlichen Anforderungen der aufgeführten Richtlinien und Normen erfüllt.
Richter Chemie-Technik GmbH confirms that the basic requirements of the above specified directives and standards have been fulfilled.

Bevollmächtigt für die Zusammenstellung der technischen Unterlagen nach 2006/42/EG:
Authorised person compiled the technical files according to 2006/42/EG:

A. Linges

Kempen, 01.07.2010



G. Kleining
Leiter Forschung & Entwicklung
Manager Research & Development

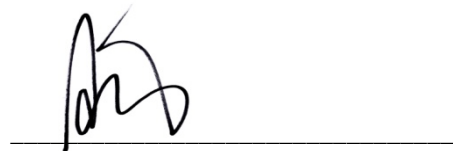

A. Linges
Leiter Qualitätsmanagement
Quality Manager

Safety Information / **Declaration of No Objection** Concerning the Contamination of Richter-Pumps, -Valves and Components

1 SCOPE AND PURPOSE

Each entrepreneur (operator) carries the responsibility for the health and safety of his employees. This extends also to the personnel, who implements repairs with the operator or with the contractor.

Enclosed declaration is for the information of the contractor concerning the possible contamination of the pumps, valves and component sent in for repair. On the basis of this information for the contractor is it possible to meet the necessary preventive action during the execution of the repair.

Note: The same regulations apply to repairs **on-site**.

2 PREPARATION OF DISPATCH

Before the dispatch of the aggregates the operator must fill in the following declaration completely and attach it to the shipping documents. The shipping instructions indicated in the respective manual are to be considered, for example:

- Discharge of operational liquids
- remove filter inserts
- lock all openings hermetically
- proper packing
- Dispatch in suitable transport container
- Declaration of the contamination fixed **outside!!** on the packing

Declaration about the Contamination of Richter Pumps, -Valves and Components

The repair and/or maintenance of pumps, valves and components can only be implemented if a completely filled out declaration is available. If this is not the case, delay of the work will occur. If this declaration is not attached to the devices, which have to be repaired, the transmission can be rejected.

Every aggregate has to have it's own declaration.

This declaration may be filled out and signed only by authorized technical personnel of the operator.

| | | | |
|--|---|--|---|
| Contractor/dep./institute : _____ | | Reason for transmitting <input checked="" type="checkbox"/> Please mark the applicable | |
| Street : _____ | | Repair: <input type="checkbox"/> subject to fee <input type="checkbox"/> Warranty | |
| Postcode, city: _____ | | Exchange: <input type="checkbox"/> subject to fee <input type="checkbox"/> Warranty | |
| Contact person: _____ | | <input type="checkbox"/> Exchange/ Replacement already initiated/received | |
| Phone : _____ Fax : _____ | | Return: <input type="checkbox"/> Leasing <input type="checkbox"/> Loan <input type="checkbox"/> for credit note | |
| End user : _____ | | | |
| A. Details of Richter-product: | | Failure description: | |
| Classification: _____ | | _____ | |
| Article number: _____ | | Equipment: _____ | |
| Serial number: _____ | | Application tool: _____ | |
| _____ | | Application process: _____ | |
| B. Condition of the Richter-product: | | Contamination : | |
| | no ¹⁾ yes no | | no ¹⁾ yes |
| Was it in operation ? | <input type="checkbox"/> <input type="checkbox"/> <input checked="" type="checkbox"/> | toxic | <input type="checkbox"/> <input type="checkbox"/> |
| Drained (product/operating supply item) ? | <input checked="" type="checkbox"/> <input type="checkbox"/> <input type="checkbox"/> | caustic | <input type="checkbox"/> <input type="checkbox"/> |
| All openings hermetically locked! | <input checked="" type="checkbox"/> <input type="checkbox"/> <input type="checkbox"/> | flammable | <input type="checkbox"/> <input type="checkbox"/> |
| Cleaned ? | <input type="checkbox"/> <input type="checkbox"/> <input type="checkbox"/> | explosive ²⁾ | <input type="checkbox"/> <input type="checkbox"/> |
| If yes, with which cleaning agent: | _____ | mikrobiological ²⁾ | <input type="checkbox"/> <input type="checkbox"/> |
| and with which cleaning method: | _____ | radioactive ³⁾ | <input type="checkbox"/> <input type="checkbox"/> |
| | | other pollutant | <input type="checkbox"/> <input type="checkbox"/> |
| ¹⁾ if "no", then forward to D. ← ²⁾ Aggregates, which are contaminated with microbiological or explosive substances, are only accepted with documented evidence of an approved cleaning. ³⁾ Aggregates, which are contaminated with radioactive substances, are not accepted in principle. | | ↓ | |
| C. Details of the discharged materials (must be filled out imperatively) | | | |
| 1. With which materials did the aggregate come into contact ? Trade name and/or chemical designation of operational funds and discharged materials, material properties, e.g. as per safety data sheet (e.g. toxic, inflammable, caustic) | | | |
| X | Trade name: | Chemical designation: | |
| a) | _____ | | |
| b) | _____ | | |
| c) | _____ | | |
| d) | _____ | | |
| 2. Are the materials specified above harmful to health ? | | no yes | ← |
| | | <input type="checkbox"/> <input type="checkbox"/> | |
| 3. Dangerous decomposition products during thermal load ? | | <input type="checkbox"/> <input type="checkbox"/> | |
| If yes, which ones ? | | _____ | |

D. Mandatory declaration: We assure that the data in this explanation are truthful and complete and as a signatory I am able to form an opinion about this. We are aware that we are responsible towards the contractor for damages, which results from incomplete and incorrect data. We commit ourselves to exempt the contractor from claims for damages of thirds resulting from incomplete or incorrect data. We are aware that we are directly responsible towards thirds, irrespective of this declaration, which belongs in particularly to the employees of the contractor consigned with the handling repair of the product.

Name of the authorized person (in block letters): _____

_____ Date _____ Signature

Company stamp

FAX**Fax No. ()****Pages (incl. cover sheet) ()****To:**

()

Richter Chemie-Technik GmbH
Otto-Schott-Straße 2
D-47906 KempenTelefon +49 (0) 21 52/146-0
Telefax +49 (0) 21 52/146-190richter-info@richter-ct.com
www.richter-ct.comContact person:
()Reference:
()Extension:
- ()E-Mail Address:
()Date:
()**Your order No.:** ()**Our Kom. No.:** ()**Serial No.:** ()

Dear Sirs,

The compliance with laws for the industrial safety obligates all commercial enterprises to protect their employees and/or humans and environment against harmful effects while handling dangerous materials.

The laws are such as: the Health and Safety at Work Act (ArbStättV), the Ordinance on Harzadous Substances (GefStoffV, BIOSTOFFV), the procedures for the prevention of accidents as well as regulations to environmental protection, e.g. the Waste Management Law (AbfG) and the Water Resources Act (WHG)

An inspection/repair of Richter products and parts will only take place, if the attached explanation is filled out correctly and completely by authorized and qualified technical personnel and is available.

In principle, radioactively loaded devices sent in, are not accepted.

Despite careful draining and cleaning of the devices, safety precautions should be necessary however, the essential information must be given.

The enclosed declaration of no objection is part of the inspection/repair order. Even if this certificate is available, we reserve the right to reject the acceptance of this order for other reasons.

Best regards
RICHTER CHEMIE-TECHNIK GMBHEnclosures

()