

SUPPLEMENTARY INSTALLATION AND OPERATING MANUAL

Translation of the original manual

Series MNK, MNK-B External Flushing of Magnetic Drive Chemical Pumps

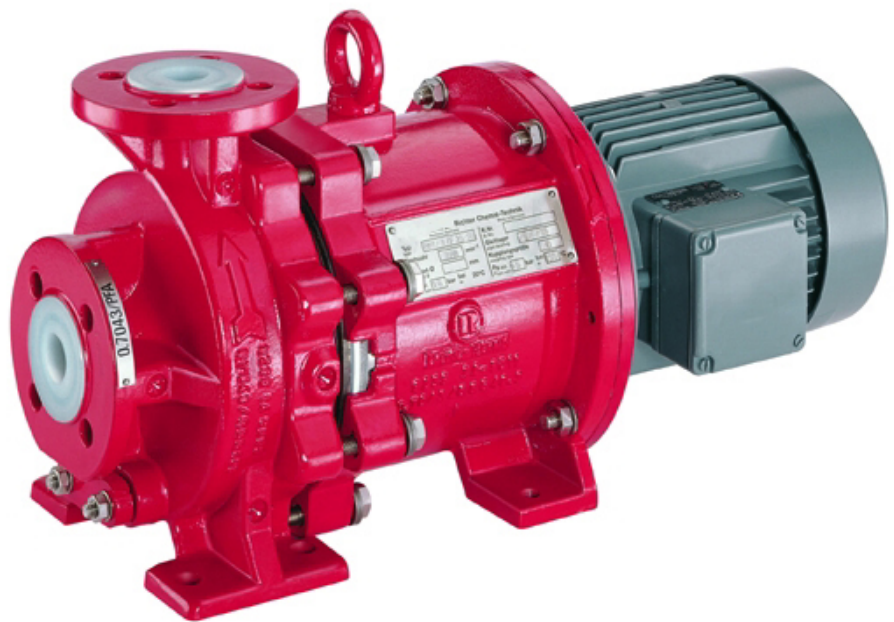

Keep for future use!

This operating manual must be strictly observed before transport, installation, operation and maintenance

Subject to change without notice.

Reproduction is generally permitted with indication of the source.

© Richter Chemie-Technik GmbH

9230-060-en Revision 10 Edition 03/2010

List of Contents

List of Contents	2	5 Commissioning / Shutdown.....	4
Relevant documents.....	2	5.1 Initial commissioning	4
1 Technical data.....	2	5.1.1 Minimum flushing pressure	4
1.1 Intended use.....	2	5.1.2 Max. flushing medium temperature.....	4
2 Safety, transport, storage and disposal	3	5.1.3 Minimum flushing flow	5
.....		5.1.4 Filling the pump housing	6
3 Product description.....	3	5.2 Operation.....	6
4 Installation.....	4	5.3 Shutdown.....	6
4.1 Safety regulations.....	4	5.4 Improper operations and their	
		consequences (examples)	7
		6 Maintenance.....	7
		6.1 Notes on dismantling.....	7
		6.2 Dismantling.....	7
		6.3 Assembly	8
		7 Sectional drawing.....	8
		7.1 Legend.....	8
		7.2 MNK with external flushing.....	9

Relevant documents

This **supplementary installation and operating manual** is only valid in conjunction with these installation and operating manuals:

MNK long life grease and oil bath lubrication	9230-050-en
MNK-B close-coupled design	9230-055-en

1 Technical data

Manufacturer :

Richter Chemie-Technik GmbH
 Otto-Schott-Str. 2
 D-47906 Kempen
 Telephone: +49 (0) 2152 146-0
 Fax: +49 (0) 2152 146-190
 E-Mail: richter-info@idexcorp.com
 Internet: <http://www.richter-ct.com>

Authorised person acc. to machinery directive 2006/42/EG: Gregor Kleining

All technical data can be found in the installation and operating manuals for the relevant pumps MNK or MNK-B.

Designation:

External flushing unit of single-stage, plastic-lined magnetic drive chemical centrifugal pumps, series MNK, permanent grease or oil bath lubrication, and MNK-B close-coupled design.

Heavy-duty horizontal design, sealless, eddy-current-free

Technical specifications to ISO 15783 and DIN ISO 5199.

Face to face according to ISO 2858 / DIN EN 22858

Flange connecting dimensions:
 DIN EN1092-2, shape B (ISO 7005-2, shape B) PN 16 or flanges drilled to ASME 16.5, Class 150

ATEX 95 Directive 94/9/EC

Machine Directive 2006/42/EC

Admissible ambient conditions for pumps acc. to directive 94/9/ EG (ATEX 95) :

Ambient temperature range: - 20 °C to + 40 °C
 (higher temperature after consulting the manufacturer)

Ambient pressure range: 0,8 bar_{abs} to 1,1 bar_{abs}.

1.1 Intended use

Richter pumps of the series MNK, MNK-B are plastic-lined, magnetic drive centrifugal pumps for the leak-free conveyance of aggressive, toxic, pure and inflammable liquids.

The pump is equipped with a permanent magnet, synchronous drive.

Field of application:

Flushing of the plain bearings with a solids-free external medium which is compatible with the process liquid.

With this facility the magnetic drive pump is suitable for all types of solids for which mechanical seal pumps are also used. Grain size <2 mm.



In addition to the intended use mentioned in the installation and operating manuals

MNK long life grease and oil bath lubrication

9230-050-en

MNK-B close-coupled design

9230-055-en

the following applies to external flushing:

The observance of the specified physical limits is important for perfect functioning and safe operation, especially with regard to explosion protection to prevent potential sources of ignition:

- ◆ Observance of the minimum flushing flow. The pump may only be put into operation when the flushing medium flow is available! See table in **Section 5.1.3.**

Risk: Lack of lubrication of the plain bearings.

Result: Inadmissible rise in temperature

- ◆ Observance of the minimum flushing pressure.

Risk: Lack of lubrication of the plain bearings.

Result: Inadmissible rise in temperature

- ◆ Max. flushing medium temperature must not be exceeded.

Risk: Lack of lubrication of the plain bearings.

Result: Inadmissible rise in temperature

- ◆ When the pump is switched off and evacuated, the flushing medium flow may only be switched off when the pump is completely emptied.

Risk: Lack of lubrication of the plain bearings.

Result: Inadmissible rise in temperature

- ◆ The suction valve must not be closed when pump at a standstill in order to prevent the medium entering the can chamber.

Risk: Lack of lubrication of the plain bearings.

Result: Inadmissible rise in temperature

- ◆ Incompatibility of the flushing medium and process liquid can cause inadmissible modes of operation, e.g. inadmissible temperature rise due to exothermal reaction, hardening or agglomeration of the medium, inadmissible gas formation etc.

- ◆ The entire outer surface must have free contact with the surroundings.

- ◆ When flushing operations are under way, it must be ensured that an excessive sedimentation of dust is prevented (poss. regular cleaning) in order to prevent the surface heating to above the admissible temperature.

- ◆ Flushing may only take place when the pump is filled with the medium. During evacuation the formation of a potentially explosive atmosphere must be prevented with the use of inert gas.

- ◆ The flushing unit must be grounded to be conductive to ensure safe operation. The conductive grounding of the flushing unit can most easily be achieved by using tooth lock washers at a grounded flange.

- ◆ Electric peripherals, e.g. pressure, temperature, flow sensors etc., must comply with the valid safety requirements and explosion protection regulations.

2 Safety, transport, storage and disposal

The relevant chapters in the adjacent installation and operating manuals apply to safety, transport, storage and disposal.

This supplementary operating manual is only valid in conjunction with the following installation and operating manuals:

MNK long life grease and oil bath lubrication

9230-050-en

MNK-B close-coupled design

9230-055-en

3 Product description

The housing dimensions, power ratings and technical requirements of the pump series MNK comply with ISO 2858 / DIN EN 22858 / ISO 15783 / DIN ISO 5199. The technical requirements of VDMA 24279 are satisfied.

The **sectional drawing** shows the external flushing unit. See **Section 7.1.**

The flushing medium flows into the can chamber and from there through the plain bearings into the pump housing.

The transition pipe **721** of the flushing connection is screwed into the plain bearing pedestal and sealed with an O-ring **412/2**.

If the external flushing unit is retrofitted, the housing **100** and bearing pedestal **330** must be adapted.

In contrast to a normal plain bearing pedestal, the plain bearing pedestal for the flushing connection has no axial openings through which the process medium could enter the can chamber.

4 Installation

4.1 Safety regulations



Equipment which is operated in potentially explosive areas must satisfy the explosion protection regulations.



People with a pacemaker are at risk from the strong magnetic field of the magnetic drive. It may be life-threatening for them to stay at a distance of less than 500 mm from the pump.

The transition pipe is supplied pre-assembled. If other feed lines have been ordered, they are supplied dismantled to facilitate transport. They are then re-assembled using the drawing provided.



It is recommended to install a flow monitor in the flushing line. If the minimum flushing flow is undershot, this sensor then triggers an alarm or the motor is shut off.

5 Commissioning / Shutdown

The general commissioning/shutdown procedures have already been described in the installation and operating manuals of the pumps of the series MNK, and MNK-B. They relate, for example, to work or inspections of the bearing pedestal, coupling and motor. At this juncture the flushing procedure is described in conjunction with the venting and filling of the pump.

5.1 Initial commissioning

Normally, the pumps have already been test-run with water. Unless special agreements have been made, there could still be residual amounts of water in the pump. This must be noted in view of a possible reaction with the process medium.

5.1.1 Minimum flushing pressure

Minimum flushing pressure required =

$$p_S + (p_D - p_S)/2$$

p_S = Pressure at the suction nozzle

p_D = Pressure at the discharge nozzle

5.1.2 Max. flushing medium temperature

The owner of the plant must ensure that the working temperature laid down is observed.

Table 1 and 3 below contains the admissible temperature limits of the flushing medium as a function of the temperature classes according to EN 13463-1.

Table 1 for series MNK

Temperature class acc. to EN 13463-1	Limit value of the temperature of the flushing medium			
Lining material	PE-UHMW	PFA/PTFE		
Can material ⁴⁾	CFK-F	CFK-F	CFK-H	CFK-Polyimid
T6 (85 °C)	not certified to ATEX			
T5 (100 °C)				
T4 (135 °C)	90 °C ¹⁾	125 °C ^{1) 2)}	125 °C ^{1) 2)}	125 °C ^{1) 2)}
T3 (200 °C)	90 °C	150 °C	180 °C	180 °C ³⁾
T2 (300 °C)	90 °C	150 °C	180 °C	180 °C ³⁾
T1 (450 °C)	90 °C	150 °C	180 °C	180 °C ³⁾

- 1) Long life grease lubrication : no restriction.
 Oil bath lubrication : standard version with shaft seal
T4 is valid during operation only up to and including 50 Hz,
T3 more than 50 Hz
T4 labyrinth seal (special design)

- 2) The limit values specified for the temperature of the flushing medium are determined for the most unfavourable case (high speed, low flow, low heat capacity of the medium,). Under favourable operating conditions the limit values specified may be increased by up to 5 K after consultation with the manufacturer.

- 3) Consult the manufacturer for higher temperatures of the flushing medium.

- 4) The can material has been list in the data sheet.

Table 2 and 3 for series MNK-B

The following always applies: No inadmissible temperatures may be introduced into the motor and the specifications of the motor manufacturer must be observed.

The temperature limits of the fluid given in **Table 3** only apply when motors are used where the motor manufacturer permits at least the following temperatures for the motor flange and motor shaft:

Table 2

Temperature class	Motor flange	Motor shaft
T6	70 °C	70 °C
T5	70 °C	80 °C
T4	75 °C	85 °C
T3	80 °C	100 °C
T2	80 °C	100 °C
T1	80 °C	100 °C

At the same time the specified max. admissible ambient temperature of 40 °C must not be exceeded.

Table 3

Temperature class acc. to EN 13463-1		Limit value of the temperature of the liquid		
Lining material		PE-UHMW	PFA/PTFE	
Can material ²⁾		CFK-F	CFK-F	CFK-H
T6	(85 °C)	75 °C ¹⁾	75 °C ¹⁾	75 °C ¹⁾
T5	(100 °C)	90 °C	90 °C ¹⁾	90 °C ¹⁾
T4	(135 °C)	90 °C	125 °C ¹⁾	125 °C ¹⁾
T3	(200 °C)	90 °C	150 °C	180 °C
T2	(300 °C)	90 °C	150 °C	180 °C
T1	(450 °C)	90 °C	150 °C	180 °C

1) The limit values specified for the temperature of the medium at the pump inlet are determined for the most unfavourable case (high speed, low flow, low heat capacity of the medium, ...). Under favourable operating conditions the limit values specified may be increased by up to 5 K after consultation with the manufacturer.

2) The can material has been list in the data sheet.

In the case of motors with the type of protection "increased safety", no or low temperature entries are generally permitted for the motor shaft and motor flange related to an ambient temperature of 40 °C.

In these cases the max. admissible medium temperature is 20 K above the temperature which may be introduced into the motor.

e.g.: Max. motor shaft temperature: 60°C

Max. motor flange temperature: 65°C

This results in a maximum medium temperature for the pump of **80 °C (60 °C + 20 K)**.

5.1.3 Minimum flushing flow

The required flushing medium flow depends on the amount of heat to be dissipated and the quantity of lubricant needed for the plain bearings. The amount of heat to be dissipated is determined by the friction values of the plain bearings and the inner magnet assembly and by the specific heat capacity of the flushing medium used.

The following formulas may be used to calculate the required flushing medium flow. It should be noted that the flushing flow must never be set lower than the minimum value also given. The higher value is **always** decisive.

Q flushing quantity [l/h]

n pump speed [rpm]

For groups, see installation and operating manuals of the relevant pump in **Section 1**.

Group 1.1

$$Q = \left(\frac{n}{1500} \right)^2 \times 10 \quad (\text{but min. } 15 \text{ l/h})$$

Group 1.2

$$Q = \left(\frac{n}{1500} \right)^2 \times 15 \quad (\text{but min. } 20 \text{ l/h})$$

Group 1.3

$$Q = \left(\frac{n}{1500} \right)^2 \times 20 \quad (\text{but min. } 25 \text{ l/h})$$

Group 2

$$Q = \left(\frac{n}{1500} \right)^2 \times 30 \quad (\text{but min. } 30 \text{ l/h})$$

The values determined apply to the flushing medium water with a specific heat capacity of 4187 J/kg * K.

They guarantee a temperature rise in the flushing flow of < 10 K. If flushing media with a different heat capacity are used, the temperature rise must be recalculated using the following formulas.

Δt	temperature, increase of the flushing medium[K]	
Q	flushing quantity	[l/h]
n	pump speed	[rpm]
c	specific heat of the flushing medium	$\left[\frac{\text{J}}{\text{kg} \times \text{K}} \right]$

Group 1.1

$$\Delta t = \frac{\left(\frac{n}{1500} \right)^2 \times 85 \times 4187}{Q \times c}$$

Group 1.2

$$\Delta t = \frac{\left(\frac{n}{1500} \right)^2 \times 130 \times 4187}{Q \times c}$$

Group 1.3

$$\Delta t = \frac{\left(\frac{n}{1500} \right)^2 \times 170 \times 4187}{Q \times c}$$

Group 2

$$\Delta t = \frac{\left(\frac{n}{1500} \right)^2 \times 215 \times 4187}{Q \times c}$$

If this results in a Δt of >10k, a check must be made using this formula whether the respective limit of the flushing medium temperature is observed.

$$T_{\text{act.}} + \Delta t \leq T_{\text{limit}}$$

$T_{\text{act.}}$ = actual temp. of the flushing medium in °C.

T_{limit} = corresp. temperature limit from table 1 or 3 in °C.

If the limit is not observed, the flushing flow must be increased accordingly.

5.1.4 Filling the pump housing

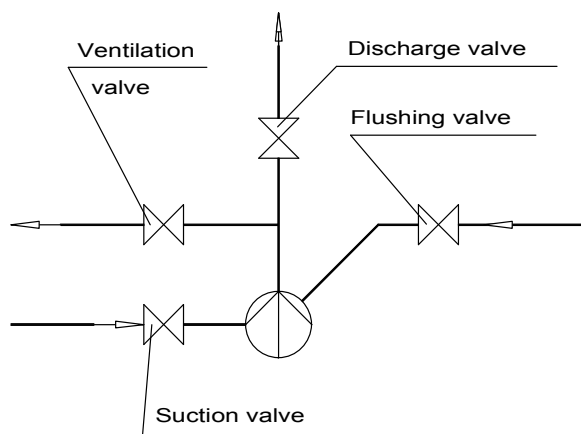

9299-00-5013.4-01.1

Fig. 1

- Check whether all the flange connections are tightened. These include the suction flange, discharge flange, housing flange and evacuation flange.

MNK: When tightening the housing bolts, make sure that the bracket is undone. Otherwise the pump could be subjected to stress.

MNK-B: When tightening the housing bolts, undo the screws in the lantern.

See Section 5.3 in the relevant installation and operating manual.

- Create venting possibility by opening the discharge valve.
- If a venting line is connected between the pump and the discharge valve, the venting valve may optionally be opened.
- Open flushing valve.
- Observe venting operation until no air but only flushing medium emerges.
- Open suction valve.
- Observe venting operation again until no more air emerges.
- **Only MNK:** Turn pump shaft several times at the coupling.
- Observe venting operation again until no more air emerges.
- Close discharge valve and venting valve.
- The suction valve and flushing valve remain open.

The venting procedure is now completed. Further commissioning can be continued using the pump operating manual.

5.2 Operation

It must be ensured that flushing medium constantly flows through the pump, e.g. by the installation of a flow monitor. The flushing medium must remain in operation even when the pump is switched off.

The suction side of the pump must also remain opened during pump standstill so that the flushing medium can continue to flow and the process medium cannot enter the can.

5.3 Shutdown

Only close the flushing valve if the pump is to be evacuated or dismantled.



It must be noted that the can chamber has to be drained via the flushing connection.



During evacuation or flushing of the pump, observe the local regulations. If the pump is to be returned to the company's own workshops or the manufacturer's, it must be cleaned especially thoroughly.

See also **Section 3.1** of the respective installation and operating manual.

5.4 Improper operations and their consequences (examples)



Inadmissible modes of operation, even for a short time, can result in serious damage to the unit.

In connection with explosion protection, potential sources of ignition (overheating, electrostatic and induced charges, mechanical and electric sparks) may result from these inadmissible modes of operation; their occurrence can only be prevented by adhering to the intended use.

Pump is started up without an adequate flow of flushing medium :

- ◆ The process medium penetrates the can chamber and jeopardises functionality.

The flushing medium is stopped before the pump is evacuated :

- ◆ The process medium penetrates the can chamber and jeopardises functionality.

The suction valve is closed when the pump is at a standstill :

- ◆ The flushing medium can no longer flow into the pump if the back pressure is too high.

The suction line is not or not completely open :

- ◆ Pump cavitates - material damage to the pump and plain bearings
- ◆ Pump does not attain the necessary delivery head or flow rate.
- ◆ Pump is destroyed due to overheating.

Overrun of the admissible gas content:

- ◆ The flow may stop.
- ◆ Switch pump and vent off for renewed conveyance.
- ◆ Make sure that the gas content is not exceeded, as described in the intended use.

Regulation of pump with the suction valve :

- ◆ Cavitation. The flow is only to be regulated on the discharge side.
- ◆ Discharge valve completely closed:
 - ◆ Pump is destroyed due to overheating.
 - ◆ Excessive shaft deflection with consequences for the plain bearings.
 - ◆ Excessive load on the plain bearings with consequences for their service life.

Discharge valve completely open :

- ◆ Pump cavitates particularly severely with the discharge line emptied.
- ◆ Motor and magnetic drive are overloaded.
- ◆ Risk of pressure surges.

Suction valve and discharge valve closed :

- ◆ Destruction due to rapid overheating and sharp rise in pressure.

6 Maintenance

6.1 Notes on dismantling

All repair and maintenance work is to be performed by qualified staff using appropriate tools and original spare parts.

Is the necessary **documentation** available?

Has the pump been taken out of operation, evacuated and flushed correctly?

See also **Section 5.3**.

If the flushing medium fails, the process liquid may enter the flushing medium feed line. Protective clothing in accordance with the regulations must therefore be worn.

The pump is dismantled and assembled in accordance with the operating manual. Care must be taken to ensure that the flushing connection is in the correct position.

6.2 Dismantling

- Remove flushing valve or any elbow provided **720/1**.
- Undo lock nut **920/7**.
- Unscrew transition pipe **721/1**.
- Remove support **732**.
- Remove O-ring **412/2** using a feeler gauge (0.3 mm).

6.3 Assembly

- Insert O-Ring **412/2** carefully into the groove of the plain bearing pedestal **339**.
- Loosely position support **732/1** and partially screw in hex. socket screw **914/2** with lock washer **934/3**. There is still movement in the support.
- Screw lock nut **920/7** onto transition pipe **721/1**.
- Screw transition pipe **721/1** until the support **732** stands off ca. 0,5 – 1 mm from the plain bearing pedestal **339** (Caution! The flange bores are at 45° to the axis).
- Finally tighten hex. socket screw **914/2**. Tightning torque 10 Nm.
- Secure transition pipe **721/1** with lock nut **920/7**. Tightning torque 50 Nm.
- Check with a gauge (approx. 2 mm Ø) whether there is a free passage into the plain bearing pedestal.

Further assembly in accordance with the drawing in **Section 7.1**.

7 Sectional drawing

7.1 Legend

339	plain bearing pedestal	732/x	support
412/2	o-ring	901/8	hex. screw
557/3	contact disc	914/2	hex. socket screw
720/1	elbow	920/x	hex. nut
721/1	transition pipe	934/3	lock washer

Pump size	X ₁	X ₂	Y ₁	Y ₂	Z ₁
25-25-125	178	--	112	--	45
25-25-160	--	280	--	262	40
50-32-125	178	--	112	--	45
50-32-160	--	280	-	262	40
50-32-200	213	--	160	--	50
65-40-200	213	--	160	--	50
80-50-160	--	280	--	262	40
80-50-200	213	--	160	--	50
80-50-250	256	--	180	--	62
125-80-200	256	--	180	--	63
125-100-200	256	--	200	--	63

Dimensions in mm

7.2 MNK with external flushing

