

INSTALLATION AND OPERATING MANUAL

Translation of the original manual

Series MPB

Peripheral Pumps with Magnetic Drive Close-coupled design size 25-25-115

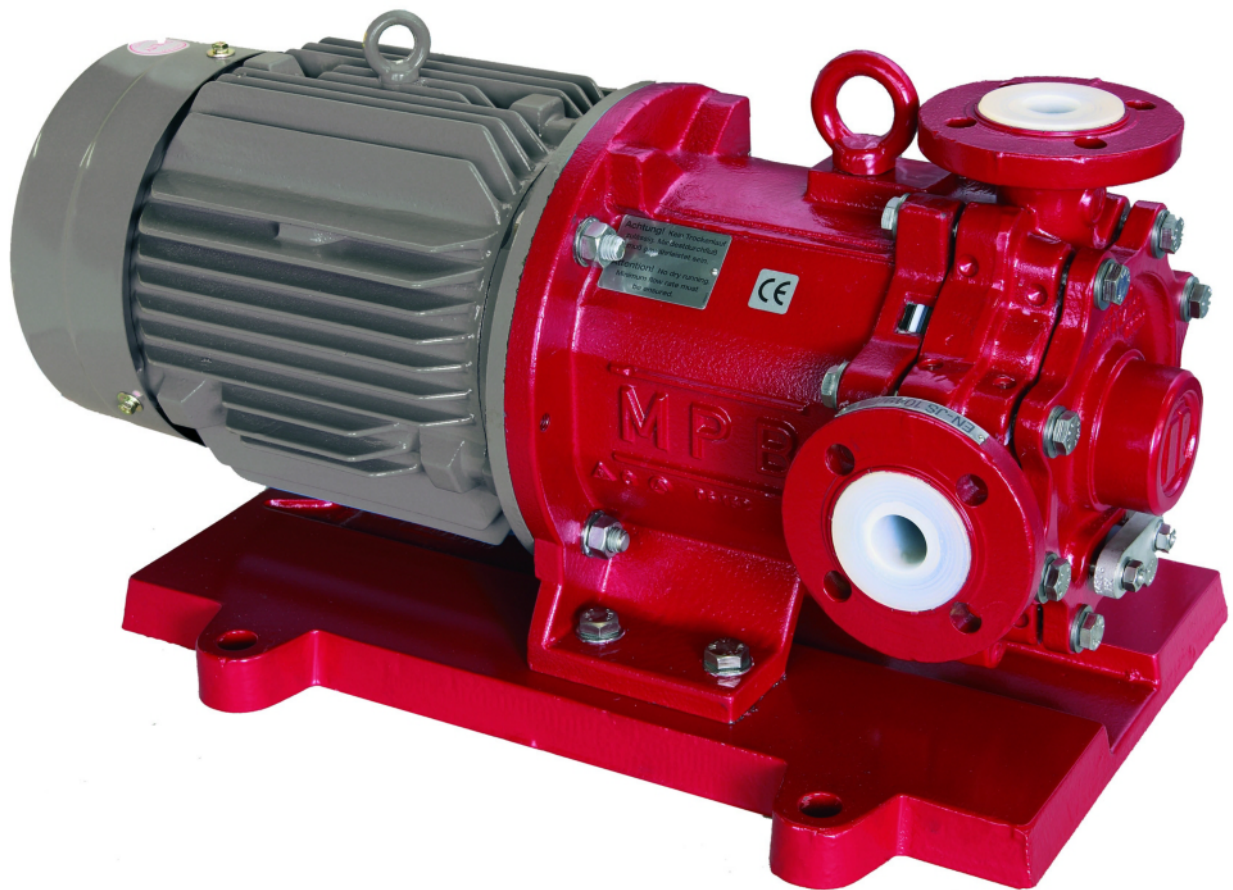

Keep for future use!

This operating manual must be strictly observed before transport, installation, operation and maintenance

Subject to change without notice.

Reproduction is generally permitted with indication of the source.

© Richter Chemie-Technik GmbH

9240-050-en Revision 10 Edition 03/2010

List of Contents

List of Contents	2	6 Commissioning / Shutdown	14
Relevant documents.....	3	6.1 Initial commissioning.....	14
1 Technical data.....	3	6.1.1 Filling the pump housing.....	14
1.1 Tightening torques.....	3	6.1.2 Start-up	14
1.2 Type plate, dry-running, ATEX-and housing markings.....	4	6.2 Operating limits.....	14
1.3 Spare parts.....	4	6.2.1 Min./max. flow rate.....	14
2 Notes on safety	4	6.3 Shutdown.....	14
2.1 Intended use.....	5	6.4 Restarting	14
2.2 For the customer/operator.....	5	6.5 Improper operations and their consequences (examples).....	15
2.3 For maintenance	6	7 Maintenance.....	16
2.4 Conversion work and production of spare parts by the customer.....	6	7.1 Screw connections of the housing.....	16
2.5 Improper operation	6	7.2 Motor.....	16
2.6 Special requirements for explosion protection	6	7.3 Cleaning.....	16
2.6.1 Filling the unit	6	7.4 Stand-by pumps.....	16
2.6.2 Special operating conditions	6	7.5 Notes on dismantling	16
2.6.3 Chargeable liquids	6	7.5.1 Protective clothing.....	16
2.6.4 Identification	7	7.5.2 Magnetic fields	16
2.6.5 Check of the direction of rotation	7	7.6 Dismantling	16
2.6.6 Mode of operation of the pump	7	7.6.1 Can, can insert and intermediate ring.....	17
2.6.7 Temperature limits	7	7.6.2 Dismantling of drive unit.....	17
2.6.8 Maintenance.....	8	7.7 Notes on assembly	17
2.6.9 Electric peripheral equipment.....	8	7.8 Assembly	17
3 Transport, storage and disposal	9	7.8.1 Assembly of drive unit.....	17
3.1 Return consignments	9	7.8.2 Can, can insert and intermediate ring.....	18
3.2 Disposal.....	9	7.8.3 Housing, right-hand ring channel and right-hand bearing bush	18
4 Product description.....	10	7.8.4 Assembly housing, impeller and inner magnet assembly.....	18
5 Installation.....	11	7.8.5 Drain (if provided)	18
5.1 Safety regulations.....	11	7.9 Tests	18
5.2 Installation of pump/unit	11	8 Faults	19
5.3 Alignment of pump - motor.....	11	9 Sectional drawing.....	20
5.4 Piping.....	11	9.1 Legend sectional drawing.....	20
5.4.1 Nominal size.....	11	9.2 Sectional drawing MPB, housing in L-position	21
5.4.2 Nozzle loads.....	11	9.3 Sectional drawing MPB, housing in V-position.....	22
5.4.3 Suction line.....	12	10 Assembly aids	23
5.4.4 Supply lines.....	12	10.1 Boring template.....	23
5.4.5 Discharge line	12	10.2 Assembly/Dismantling aid for inner magnet assembly.....	23
5.4.6 Venting and draining	12	10.3 Dismantling ring	24
5.5 Pipe fittings.....	12		
5.6 Monitoring facilities.....	13		
5.7 Drive	13		
5.8 Electric connection	13		

Relevant documents

- ◆ Data sheet
- ◆ Works certificate
- ◆ Sectional drawing MPB
 - nozzle position L of the housing 9240-00-3000
 - nozzle position V of the housing 9240-00-3001
- ◆ Installation drawing 9240-00-3003
- ◆ Dimensional drawing drain connection 9240-00-3002
- ◆ Performance curves
- ◆ Spare parts list
- ◆ Operating manual and declaration of conformity motor

Appendix to the operating instructions

- ◆ Operational limits see 9240-00-3030
- ◆ Declaration of conformity with ATEX
- ◆ Declaration of conformity without ATEX
- ◆ Form for Safety Information Concerning the Contamination QM 0912-16-2001_en

On request:

- ◆ Magnetic drive data Richter TIS 0543-03-0001
- ◆ Publication: "Centrifugal Pump Operation without NSPH Problems"
- ◆ Publication "Safe Operation of Magnetic Drive Pumps"

1 Technical data

Manufacturer :

Richter Chemie-Technik GmbH
 Otto-Schott-Str. 2
 D-47906 Kempen
 Telephone: +49 (0) 2152 146-0
 Fax: +49 (0) 2152 146-190
 E-Mail: richter-info@idexcorp.com
 Internet: <http://www.richter-ct.com>

Authorised person acc. to machinery directive
 2006/42/EG: Gregor Kleining

Designation :

Peripheral pump with magnetic drive, series MPB, close-coupled design

Technical specifications to ISO 15783 and DIN ISO 5199

Flange connecting dimensions:

DIN EN 1092-2, type B (ISO 7005-2, type B) PN 16 or flanges drilled to ASME 16.5, Class 150

ATEX 95 Directive 94/9/EC

Machine Directive 2006/42/EC

Materials :

Pressure-bearing parts:

ductile cast iron EN-JS 1049 to DIN EN 1563 (0.7043 DIN 1693), carbon fibre composite material

Wetted parts:

PFA, PTFE, SSiC, FKM/FFKM, and see data sheet

Flow rate : up to 6 m³/h (at 2900⁻¹/min)

Delivery head : up to 100 m LC (at 2900⁻¹/min)

Housing discharge pressure : max. 16 bar
 detailed data see operational limits

Temperature range : - 60 °C to + 150 °C

Note: Consult the manufacturer for higher pressures and lower or higher temperatures.

Temperature classes : see Section 2.6.7

Noise capacity level : L_{WA} = ≤ 70 dB acc. to DIN EN ISO 9614-2

Admissible ambient conditions for pumps acc. to directive 94/9/ EC (ATEX 95) :

Ambient temperature range: -20°C to +40°C (higher temperature after consulting the manufacturer)

Ambient pressure range : 0,8 bar_{abs} to 1,1 bar_{abs}

Weight : See data sheet

Dimensions : See installation drawing

Size : 25-25-115

1.1 Tightening torques

Screws greased, tighten in diametrically opposite sequence.

	No. x Size	Nm
Cover flange	8 x M 10	20
Housing flange	8 x M 10	25
Drain flange	2 x M 8	10

Pipe screws, flanges to DIN/ISO

DN [mm]	No. x size [DIN/ISO]	Tightening torque [Nm]
25	4 x M 12	10

Pipe screws, DIN/ISO flanges drilled to ASME

DN		No. x size [ASME]	Tightening torque	
[mm]	[inch]		[Nm]	[in-lbs]
25	1"	4 x 1/2"	8	70

1.2 Type plate, dry-running, ATEX- and housing markings

The stainless steel type plate is firmly riveted to the lantern:

If the operator attaches his identification, it must be ensured that the pump matches the application in question.

Example of type plate:

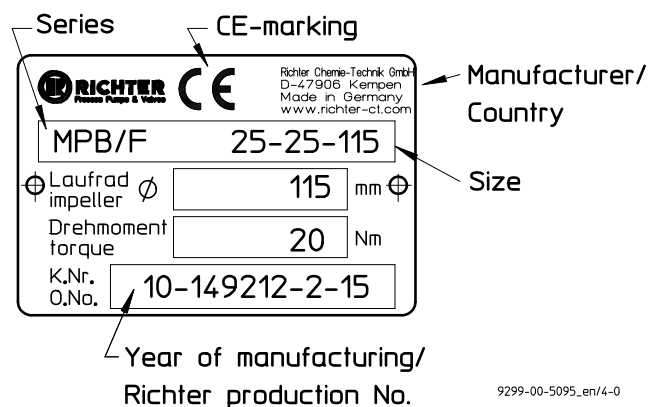

Dry-running:

Achtung! Kein Trockenlauf zulässig. Mindestdurchfluss muß gewährleistet sein.
 Attention! No dry running. Minimum flow rate must be ensured.

ATEX marking:



Housing identification:

The following are visible on the housing according to DIN EN 19:

- ◆ Nominal size
- ◆ Rated pressure
- ◆ Housing material
- ◆ Manufacturer's identification
- ◆ Melt number/Foundry identification
- ◆ Foundry date

1.3 Spare parts

Spare parts for two years of continuous operation in accordance with DIN 24296 and in consultation with the manufacturer

2 Notes on safety

This operating manual contains fundamental information which is to be observed during installation, operation and maintenance.

It must be read before installation and commissioning!

This operating manual must always be available at the place of use of the machine/plant.

In addition to the general notes on safety under the main heading "Safety", special notes on safety are included at other points and must be observed.

Installation, operation and maintenance are to be performed by qualified staff.

The area of responsibility, authority and supervision of the staff must be exactly regulated by the customer.

If the staff do not have the necessary expertise, they are to be trained and instructed.

If necessary, this can be provided by the manufacturer/supplier on behalf of the machine operator.



General hazard symbol! People may be put at risk.



Safety symbol! The pump and its function may be put at risk if this safety symbol is not observed.



EU marking! Explosion-protected equipment must be identified for work in potentially explosive areas.



Warning of a magnetic field!



Warning of electric power!



This warning sign must be used if people with a pacemaker are at risk, e.g. from a strong magnetic field.

It is imperative to observe signs attached directly to the pump / unit, e.g.:

- ◆ Direction of rotation arrow
 - ◆ Warning against dry-running
- and they are to be kept legible.

Non-observance of the notes on safety may result in the loss of any and all claims for damages.

Non-observance may involve the following hazards :

- ◆ Failure of important functions of the machine/plant.
- ◆ Failure of electronic equipment and measuring instruments due to magnetic fields.

- ◆ Risk to people and their personal property from magnetic fields.
- ◆ Risk to people from electric, mechanical and chemical effects.
- ◆ Risks to the environment through leaks of hazardous substances.

 **If the unit is used in potentially explosive areas, special attention is to be paid to the sections identified with “Ex” in this operating manual.**

2.1 Intended use

Richter pumps of the series MPB are plastic-lined peripheral pumps for the leak-free conveyance of aggressive, toxic, pure and inflammable liquids. These liquids must not contain any solids.

Gas contents of up to 30% may be entrained. If gas is entrained in an explosive area, it must be ensured that no explosive atmosphere enters the pump as a result of the gas conveyed.

The pump is equipped with a permanent magnetic synchronous drive.

 The observance of the specified physical limits is important for perfect functioning and safe operation, especially with regard to explosion protection to prevent potential sources of ignition (see **Section 2.6**):

- ◆ It must be ensured that the pump is always filled with liquid during operation.
- ◆ For safe pump operation, we recommend a flow rate which lies between 0.3 and 1.1 Q_{opt} . The maximum operating temperature must never be exceeded. See **Section 2.6.7**. In case of doubt, you must consult the manufacturer.
- ◆ The manufacturer must be consulted in the event of entrainment of gas >5% in order to avoid a lack of lubrication and dry-running. If gas is entrained in an explosive area, it must be ensured that no explosive atmosphere enters the pump as a result of the gas conveyed.
- ◆ The plant NPSH value (NPSHA) should be 0.5 m higher than the NPSH value of the pump (NPSHR). See also **Section 5.4.1**.
- ◆ Owing to its design the pump can draw in media on its own within certain operating limits. It is imperative for the pump to be filled completely prior to self-priming. For self-priming in or out of an explosive area it must be ensured that no potentially explosive atmosphere can form. This can be achieved by superimposing the plant with an inert gas (e.g. nitrogen). The medium must not exceed the medium temperature shown in the table in **Section 2.6.7** nor its boiling temperature. This can, for example, be ensured by a temperature monitor.

 Improper operation, even for a short period, may result in serious damage to the unit.

In connection with explosion protection, potential sources of ignition (overheating, electrostatic and induced charges, mechanical and electric sparks) may result from these improper operation; their occurrence can only be prevented by adhering to the intended use.

Furthermore, reference is made in this connection to the Directive 95/C332/06 (ATEX 118a) which contains the minimum regulations for improving the occupational health and safety of the workers who may be at risk from an explosive atmosphere.

 This unit must not be operated above the values specified in the data sheet as regards the fluid to be conveyed, flow rate, speed, density, delivery head and operating temperature as well as the motor rating.

The instructions contained in the operating manual or contract documentation must be observed; if necessary consult the manufacturer.

All important features are documented in the data sheet included in the scope of delivery.

In the event of operating conditions other than those described in the data sheet, the following are to be checked again:

- ◆ design of the pump
- ◆ design of the accessories
- ◆ resistance of the materials.

2.2 For the customer/operator

The following must be observed:

- ◆ The notes on safety contained in this operating manual,
- ◆ the prevailing regulations on accident prevention,
- ◆ in-house work, operating and safety regulations of the customer.
- ◆ Hot or cold machine parts must be protected by the customer against being touched.
- ◆ No protective facilities may be removed when the machine is in operation.
- ◆ The ring bolt **900/1** must not be removed or loosened as deposits could form between the drive magnet assembly and the lantern.  For example, overheating and thus potential sources of ignition could arise due to frictional energy.
- ◆ Hazards due to electricity are to be excluded.
- ◆ Leaks of hazardous media (e.g. explosive, toxic, hot) must be removed so that no risk arises for people and the environment. The statutory provisions are to be observed.

 Caution when using the units in potentially explosive area! Improper operation must be prevented.

2.3 For maintenance

In principle, work on the unit may only be performed when it is at a standstill.

It is imperative to observe the procedure for stopping the machine described in this operating manual. See **Section 6.3**.

Pumps which convey media which are a health hazard must be decontaminated.

All safety and protective facilities must be remounted or enabled immediately after the end of work.

In the assemble state, if the safety notes (see also **Section 5.1 and 7.5.2**) are observed, the magnetic drives do not cause any risks or have any affect on the environment.



During dismantling and assembly as well as during transport and storage of the magnetic drives as single components, the notes on safety in **Section 7.5.2** must be observed.

The points listed in **Section 6.1** must be followed before recommissioning.

2.4 Conversion work and production of spare parts by the customer

Conversion of or changes to the machine are only admissible after consultation with the manufacturer.

Original spare parts and accessories authorised by the manufacturer serve to enhance safety.

The use of other parts may annul the liability for any resultant consequences.

2.5 Improper operation

The operational safety of the machine supplied is only guaranteed if it is used properly in accordance with **Section 2.1** of this operating manual.

The operating limits specified in the data sheet must under no circumstances be exceeded.

2.6 Special requirements for explosion protection

If the units are used in potentially explosive areas, the measures and notes in **Sections 2.6.1 to 2.6.9** are imperative to guarantee the explosion protection.

2.6.1 Filling the unit



During pump operation the wetted interior of the pump must always be filled with the liquid medium.

This prevents any explosive atmosphere and the risk of dry-running.



If the customer cannot ensure this, we recommend that appropriate monitoring facilities be provided.



All auxiliary, heating and cooling systems must also be carefully filled.

2.6.2 Special operating conditions



In the standard design the can chamber and the plain bearings are cooled and lubricated by a flushing flow.

The cooling flow may be interrupted and an inadmissible rise in temperature may occur due to properties of the liquid (e.g. sticking, clogging, ingress of gas etc.). Appropriate monitoring facilities are to be provided. See **Section 5.6**.

For safe pump operation, we recommend a flow rate of 0.3 to 1.1 Q_{opt} . If the pump is operated outside this range, it must be ensured that the max. admissible flow rate according to the pump characteristic curve is not exceeded and that the max. admissible operating temperature according to **Section 2.6.7** is observed.

If the flow rate is too high, the differential pressure upstream and downstream of the plain bearings could fall so much that a lack of lubrication or dry-running may occur.

If the flow rate is too low, the medium may heat up so much owing to the fluid friction that the max. admissible surface temperature of the relevant temperature class is exceeded

Overloading, overheating, non-observance of the design data or the incorrect selection of the magnetic drive can lead to the decoupling of the inner and outer magnet assemblies. As a result, eddy currents are induced on the inner and outer magnet assemblies and an inadmissible rise in temperature may occur.

The situation is to be remedied by providing appropriate monitoring facilities. See **Section 5.6**.

The plant NPSH value (NPSHA) should be 0.5 m higher than the NPSH value of the pump (NPSHR) to prevent a lack of lubrication or dry-running of the plain bearings.

2.6.3 Chargeable liquids



For operation with chargeable liquids with a conductivity $< 10^{-8}$ S/m inert gas must be used for flushing during drain if the lining of the pump is non-conductive. See **Section 6.3**.

2.6.4 Identification

 The identification on the pump relates to the pump section. A separate declaration of conformity must be provided for the motor and for other attachments as well as corresponding identification.

Example of the identification of the pump section:

 II2GD IIC TX X.

For assembling the pump with components which are not explosion-protected (e.g. motor, shaft coupling), it is recommended to mask or remove the "potentially explosive" identification from the pump component and, if necessary, from other accessories.

In this case the declaration of conformity applies without ATEX identification.

At surface temperatures which depend primarily on operating conditions, DIN EN 13463-1 Chapter 9.3 allows no temperature class or temperature to be indicated.

The temperature class must be determined by the operator in accordance with **Section 2.6.7** "Temperature Limits".

2.6.5 Check of the direction of rotation

 If there is also a risk of explosion during the installation phase, the check of the direction of rotation must under no circumstances be conducted by briefly switching on the unfilled pump in order to prevent an inadmissible rise in temperature at the plain bearings.



We recommend you to only perform a check of the direction of rotation with filled pump and with a rotating field instrument. See also

Section 6.1.2.

2.6.6 Mode of operation of the pump

The pump may only be started with the suction side shut-off element fully opened and the discharge side shut-off element slightly opened. Start-up against a closed check valve is also possible. The discharge side shut-off element is to be regulated to the operating design point directly after run-up.

See also **Section 5.4.1.**

Operation with closed shut-off elements in the suction and/or discharge lines is not permitted!

 There is a risk that even after a short time high surface temperatures on the pump housing may occur owing to rapid heating of the liquid in the pump interior.



A rapid rise in the pressure inside the pump involves the risk of overloading to the point of bursting.



The pump must not be in operation in the unfilled or partially filled state (dry running). This results in serious damage to the pump and additional risks to the environment can arise.



Dry-running cannot only occur with an insufficiently filled interior but also in the event of high gas contents in the liquid medium.

Operation of the pump outside the admissible operating range may also lead to dry-running (e.g. due to evaporation in the interior).

2.6.7 Temperature limits



In the normal operating condition the highest temperatures are to be expected on the surface of the pump housing.

We would like to point out that, under extreme operating (medium temperature > 160°C) and ambient conditions (ambient temperature > 30°C), temperatures of over 130°C may arise on the surface of the pump housing.

In the case of liquids > 40 °C the surface temperature of the pump housing is generally lower than the temperature of the liquid as the plastic lining has an insulating effect.



If the pump is heated (e.g. heating jacket), it must be ensured that the temperature classes prescribed in the annex are observed.

The not heated pump surface must have free contact with the environment.



During operation of the pump it must be ensured that excessive deposits of dust are prevented (regular cleaning) in order to prevent the pump surface from heating to above the admissible temperature.

The plant customer must ensure that the prescribed operating temperature is observed. The maximum admissible temperature of the liquid medium at the pump inlet depends on the temperature class and the selected lining material required in each case.

The following always applies: No inadmissible temperatures may be introduced into the motor and the specifications of the motor manufacturer must be observed.

The temperature limits of the fluid given in **Table 2** only apply when motors are used where the motor manufacturer permits at least the following temperatures for the motor flange and motor shaft:

Table 1

Temperature class	Motor flange	Motor shaft
T6	70 °C	70 °C
T5	70 °C	80 °C
T4	75 °C	85 °C
T3	80 °C	100 °C
T2	80 °C	100 °C
T1	80 °C	100 °C

At the same time the specified max. admissible ambient temperature of 40 °C must not be exceeded.

Table 2 below indicates the admissible medium temperature, depending on the pump design, as a function of the temperature class in accordance with EN 13463-1.

Table 2

Temperature class accord. EN 13463-1	Limit values of the temperature of the liquid
	PFA/PFA-L
T6 (85 °C)	75 °C ¹⁾
T5 (100 °C)	90 °C ¹⁾
T4 (135 °C)	125 °C ¹⁾
T3 (200 °C)	150 °C
T2 (300 °C)	150 °C
T1 (450 °C)	150 °C

- 1) The limit values specified for the temperature of the medium at the pump inlet are determined for the most unfavourable case (high speed, low flow, low heat capacity of the medium, ...). Under favourable operating conditions the limit values specified may be increased by up to 5 K after consultation with the manufacturer.

In the case of motors with the type of protection "increased safety", no or low temperature entries are generally permitted for the motor shaft and motor flange related to an ambient temperature of 40 °C.

In these cases the max. admissible medium temperature is 20 K above the temperature which may be introduced into the motor.

e.g.: Max. motor shaft temperature: 60°C
Max. motor flange temperature: 65°C

This results in a maximum medium temperature for the pump of **80 °C (60 °C + 20 K)**..

2.6.8 Maintenance



For safe and reliable operation, it must be ensured with regular inspection intervals that the unit is properly serviced and kept in a perfect technical condition.

If auxiliary systems (e.g. external flushing, cooling, heating) are installed, a check must be made to see whether monitoring facilities are required to safeguard their operation.

In regard to media containing solids, the maintenance intervals must be set by the operator in accordance with the conditions of operation.

2.6.9 Electric peripheral equipment

Electric peripheral equipment, e.g. pressure, temperature and flow sensors etc. must comply with the prevailing safety requirements and explosion protection provisions.



Regular checks of the motor bearings in accordance with the operating manual of the motor manufacturer. Observe ATEX notes.

3 Transport, storage and disposal



The pump or the unit must be transported properly. It must be ensured that during transport the pump/unit remains in the horizontal position and does not slip out of the transport suspension points.

The ring bolts of the pump and the motor must be used to transport the entire unit, i.e. pump with baseplate and motor. See **Fig. 1**.

The slinging ropes must not be attached to free shaft ends.

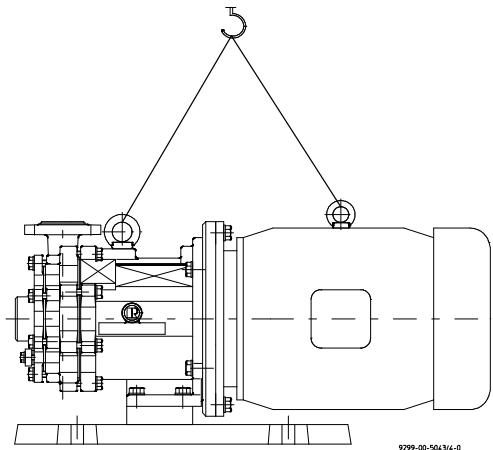

Fig. 1

Directly after receipt of the goods, the consignment must be checked for completeness and any in-transit damage.

Damaged pumps must not be installed in the plant.



When unpacking magnetic drives as single parts, the relevant notes in **Section 7.5.2** must be observed.

Handle goods carefully to prevent damage.

Flange covers serve as protection during transport and must not be removed.

If the unit is not installed immediately after delivery, it must be put into proper storage.

The product should be stored in a dry and vibration-free, well ventilated room at as constant a temperature as possible.

Elastomers are to be protected against UV light.

In general, a storage period of 10 years should not be exceeded. An admissible storage period of 4 years applies to elastomers made of NBR.



If magnetic drives are stored as single parts, the relevant notes in **Section 7.5.2** are to be observed.

In the case of **prolonged storage** conservation agents on machined component surfaces and packing with a desiccant may be necessary.

3.1 Return consignments

Pumps which have conveyed aggressive or toxic media must be well flushed and cleaned before being returned to the manufacturer's works.



It is **imperative** to enclose a **safety information sheet / general safety certificate** on the field of application with the return consignment.

Pre-printed forms are enclosed with the installation and operating manual.

Safety precautions and decontamination methods are to be mentioned.

3.2 Disposal

Parts of the pump may be contaminated with medium which is detrimental to health and the environment and therefore cleaning is not sufficient.



Risk of personal injury or damage to the environment due to the medium or oil!

- ◆ Wear protective clothing when work is performed on the pump.
- ◆ Prior to the disposal of the pump:
 - Collect any medium, oil etc. which has escaped and dispose of it in accordance with the local regulations.
 - Neutralise any medium residues in the pump.
- ◆ Separate pump materials (plastics, metals etc.) and dispose of them in accordance with the local regulations.



4 Product description

Technical requirements of the pump series MPB correspond to ISO 15783 / DIN ISO 5199. The technical requirements of the VDMA 24279 are satisfied.

The peripheral pump belongs to the family of ring channel pumps. It is used when large delivery heads are to be attained at relatively low flow rates.

The **sectional drawing** shows the design of the pump. See **Section 9.2 and 9.3**.

All components which come into contact with the medium are either plastic-lined or made of other resistant materials, e.g. silicon carbide.

The nozzle position of the housing **100** may be either  shaped or  shaped. See sectional drawing in **Sections 9.2 and 9.3**.

The impeller **230** has 2 lip seals. These are hydraulically pressed against the ring channels. The gap losses are therefore considerably reduced.

The distance ring **504** prevents the right-hand bearing sleeve from "drifting".

The stud **560/1** holds the ring channels in the correct position.

All openings in the rear of the housing, apart from the lowest one, are sealed with the centering gaskets **415/3**.

The lowest one remains open:

1. for draining
2. for the flushing flow

The **flushing flow** moves through the lowest opening into the can insert. It is returned into the housing through the right-hand bearing.

The can and the cover are **vented** through the bearings.

The **left-hand ring channel** is identical to the **right-hand ring channel**.

The cover **160** seals the housing and at the same time exerts pressure on the ring channels.

Further design details can be seen in the sectional drawings in **Sections 9.2 and 9.3**.

Additional information can also be found in the **brochure**.

5 Installation

5.1 Safety regulations

Equipment which is operated in potentially explosive areas must satisfy the explosion protection regulations.



People with a pacemaker are at risk from the strong magnetic field of the magnetic drive. It may be life-threatening for them to stay at a distance of less than 500 mm to the pump.



5.2 Installation of pump/unit



The structural work must be prepared in accordance with the dimensions in the installation drawing.

Method of installation: on a grouted base plate and firm foundation

Align base plate on the ground foundation.

Insert foundation bolts and grout base plate.

Do not tighten the foundation bolts uniformly and firmly until the mortar has set.

Other possibilities of alignment are:

- ◆ 4-point-alignment
- ◆ 4-point-alignment with base plate.



As soon as additional installations are mounted, the stability of the entire unit installed without a foundation must be checked.

5.3 Alignment of pump - motor



Special notes of the motor manufacturer are to be observed.

- Use supports in the direct vicinity of the bolts foundation/base plate.

5.4 Piping

Before the pump is installed, both the suction and supply lines as well as the discharge line are to be cleaned.

Dirt or damage to the sealing surfaces is best avoided if the flange covers remain on the flanges until just before installation.

Use flange gaskets suitable for the medium.

The screw tightening torques in **Section 1.1** are to be observed for tightening the flange screws.

5.4.1 Nominal size

The operating design point of a centrifugal pump lies at the intersection of the pump curve and the pipe curve, see **Fig. 2**. The pump curve is provided by the pump manufacturer. The pipe curve is determined using diagrams or PC programs.

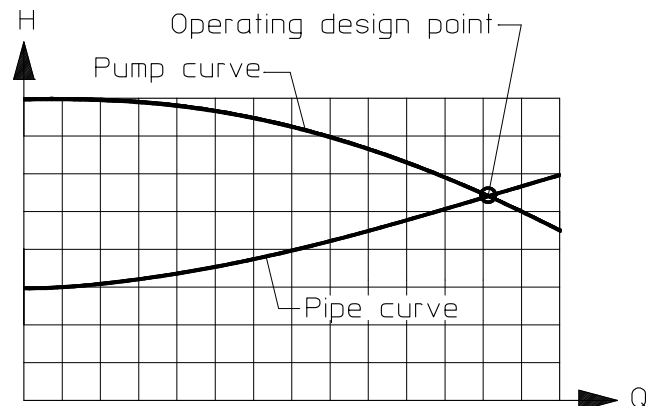

9299-00-5009_en/4-0

Fig. 2

Under no circumstances can the nominal size of the piping be derived from the connected nominal size of the pump.

The pipe nominal size can also be determined using the flow rate as a rough guide.

$$v \text{ (m/s)} = \frac{Q \text{ (m}^3\text{/s)}}{A \text{ (m}^2\text{)}}$$

The velocity in the suction line should not exceed 2.0 m/s and 5.0 m/s in the discharge line.

When determining the suction line nominal size, the NPSH value (net positive suction head) must also be observed. The **NPSHR value** required for the pump is specified in the data sheet.



The NPSHR available in the plant should be at least 0.5 m higher than the NPSHR required for the pump. Otherwise, this will lead to a drop in the delivery head, cavitation or even failure of the pump.

5.4.2 Nozzle loads

The pump can be subjected to nozzle loads in accordance with ISO 5199.

Changes in the length of the piping caused by temperature are to be allowed for by appropriate measures, e.g. the installation of expansion joints.

5.4.3 Suction line

The suction lines must always be laid on a rising gradient towards the pump. Otherwise, gas bubbles may form which considerably reduce the suction line cross section. Eccentric transition elements must be installed between different pipe diameters.

Valves which disrupt the course of flow should not be installed directly upstream of the pump.

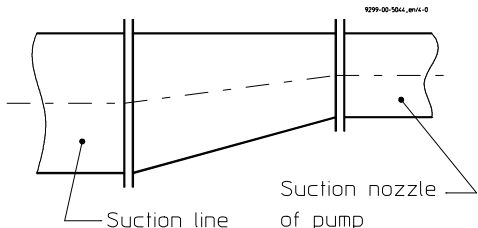

Fig.3

A volume of liquid in the suction line permits self-priming with a peripheral pump.

Application example for a liquid similar to water, 20°C, venting time approx. 5 minutes.

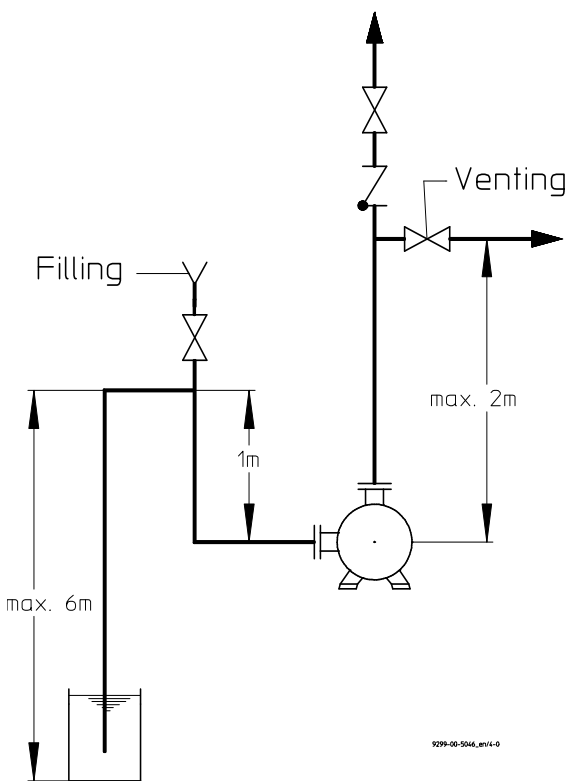

Fig. 4

5.4.4 Supply lines

Supply lines should vent towards the reservoir and are therefore to be laid with a constant downward gradient towards the pump. Should the piping internals upstream of the pump be horizontal, a low point can, of course, be located upstream of these internals. From here the pipe is then laid with an upward gradient to the pump so that the gas bubbles which form here can escape through the pump. Valves which disrupt the course of flow should not be installed directly upstream of the pump.

5.4.5 Discharge line

Do not arrange the shut-off valve directly above the pump but initially provide a transition section. The discharge nozzle velocity of the medium can – if necessary – be reduced.

5.4.6 Venting and draining

Venting can take place into the discharge line or upstream of the discharge valve. A venting line can also be used as a bypass, drain or flushing line.

The pump housing is fitted with a drain connection as a standard feature. Optionally, the drain bore can be drilled. For boring template, see **Section 10.1**.

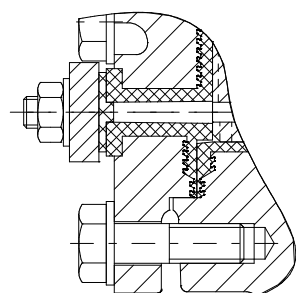

Fig. 5

5.5 Pipe fittings

The following pipe fittings are available from Richter on request:

- ◆ Shut-off valves
- ◆ Check valves
- ◆ Sight glasses
- ◆ Priming vessels
- ◆ Strainers
- ◆ Pressure

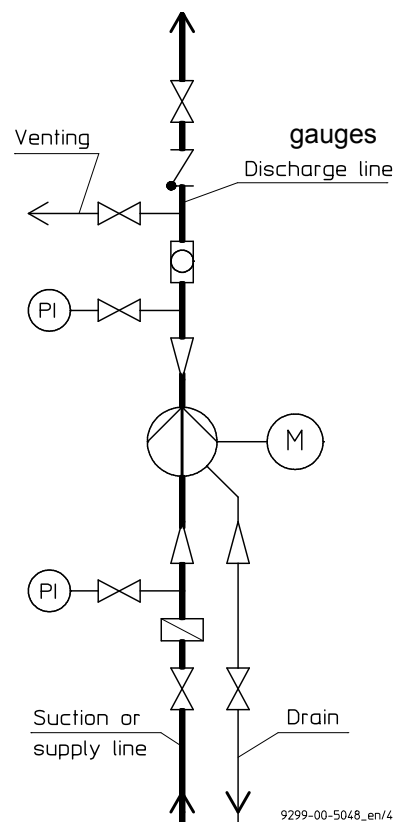

Fig. 6

5.6 Monitoring facilities



Appropriate monitoring facilities are to be recommended, depending on the requirements placed on operational safety and availability of the unit.

Richter provides information on request and can supply:

- ◆ Flow meters
- ◆ Filling level indicators
- ◆ Motor load monitors
- ◆ Temperature monitors
- ◆ Can monitors
- ◆ Leak monitors

You can obtain the publications "Safe Operation of Magnetic Drive Pumps" and "The Operation of Centrifugal Pumps without NPSH Problems" on request.

5.7 Drive

The power consumption of the pump at the operating design point is specified in the data sheet and works certificate. If the operating design point was not known when the pump was dispatched, the power consumption can be read off the appropriate performance curves. The max. density, the max. viscosity and a safety margin are to be allowed for.

Care must be taken when selecting the motor size to ensure that the excess power is not too great. During start-up the magnetic drive could otherwise stop.

The magnetic drive rating at a nominal speed of 2900 rpm is given in the pump data sheet.

If the motor power exceeds this rating, it is necessary to check the stoppage of the magnetic drive.

The same also applies if the required drive rating exceeds 80 % of the magnetic drive rating.

Consult Richter if necessary.

Different operating data can be achieved without changing the pump through the use of different speeds, e.g. by means of a frequency converter.

The pump with base plate and motor is illustrated in the **installation drawing**.

The **operating manual of the motor manufacturer** must be observed.



A motor with a valid ATEX certificate is to be used if employed in zone 1 and 2.

5.8 Electric connection

The operator is obligated to connect the assembly in accordance with existing regulations 8 (IEC, VDE, etc.).



Allow only a trained electrician to perform the electrical connection.

Compare the existing mains voltage with the indications on the motor's manufacturer's nameplate and choose a suitable circuit.

A motor protection device (motor-circuit switch) is urgently recommended.



Danger of explosion if the electrical installation is incorrect.



In areas at risk of explosion, IEC 60079-14 must also be observed for the electrical installation.

If the pump is mounted on a base plate, ensuring electrical conduction through the use of a chopper disk or contact disk on the housing foot and support bracket.

The assembly must be grounded in accordance with currently effective regulations, for example, on the base plate.

6 Commissioning / Shutdown

6.1 Initial commissioning

Normally, the pumps have already been test-run with water. Unless special agreements have been made, there could still be residual amounts of water in the pump. This must be noted in view of a possible reaction with the medium.

6.1.1 Filling the pump housing

- Check to see whether the screws on the suction flange, discharge flange, housing flange and drain flange are tightened. For screw tightening torques see [Section 1.1](#).
- Open the suction line fully so that the medium can flow into the pump.
- Open the discharge valve so that the air in the pump can escape.
- If air cannot be vented into the discharge line, e.g. a drop in pressure in this line is not permitted, venting must be performed upstream of the discharge valve.
- Monitor the venting operation until no air but only liquid emerges.
- Close the discharge valve again until only the minimum flow rate is obtained after the motor has been started.



6.1.2 Start-up

- Check the direction of rotation of the motor with a rotary field instrument.
- As viewed from the motor, the direction of rotation of the pump is clockwise. See also the **direction of rotation arrow** of the pump.



If no rotating field instrument is available, the motor may also be activated briefly, with the pump filled, so that it does run up. You can observe the direction of rotation through the fan hood.



The pump must not run dry during the check of the direction of rotation.

The pump must be completely filled with liquid. The maximum admissible flow rate must not be exceeded.



Otherwise the plain bearings can run dry in both cases.

- Switch the motor on.
- Set the desired flow by opening the discharge valve.



When the motor is running but the pump is not conveying, this means that the magnetic drive has stopped.

- Switch motor off immediately in order to prevent overheating of the magnet assemblies.
- Then proceeded as follows:
- Close discharge valve down to the position "minimum flow rate".
- Start motor again.

If the magnetic drive stops again, look for the cause.

6.2 Operating limits



The operating limits of the pump/unit in terms of pressure, temperature, power and speed are entered in the data sheet and it is imperative to observe them!

6.2.1 Min./max. flow rate



The operating range generally recommended lies at $0.3 Q_{opt}$ to $1.1 Q_{opt}$. See for this [Section 2.6.2](#).

6.3 Shutdown

- Close discharge valve down to the position "minimum flow rate"
- Switch motor off.
- Close discharge valve completely.

Only close the suction line if the pump is to be evacuated or dismantled.



For all work on the machine, make sure that the motor cannot be inadvertently switched on.



If the pump is to be evacuated or flushed, observe the local regulations.



If the pump has been operated with a chargeable liquid, it must be filled with inert gas (e.g. nitrogen) to prevent an explosive atmosphere.

It is recommended to wait one hour before the pump is dismantled from the plant to permit static peak charges to be eliminated.

These measures are not necessary with pumps with a conductive plastic lining.

If the pump is returned to the manufacturer's, clean the pump very thoroughly.

See also [Section 3.1](#).

6.4 Restarting

When the pump is restarted, it must be ensured that all the relative steps as described in [Section 6.1](#) are repeated, depending on the progress of the shutdown operation.

6.5 Improper operations and their consequences (examples)



Improper operation, even for a short time, can result in serious damage to the unit.

In connection with explosion protection, potential sources of ignition (overheating, electrostatic and induced charges, mechanical and electric sparks) may result from these improper operation; their occurrence can only be prevented by adhering to the intended use.

Pump is started up without medium :

- ◆ The plain bearings in the pump may be destroyed.
- ◆ Other pump components may be destroyed due to overheating.

Suction line not opened or not opened fully :

- ◆ Pump is cavitating – material damage to pump and plain bearings
- ◆ Pump does not attain the required delivery head or flow rate.
- ◆ Pump may be destroyed due to overheating.

Discharge valve closed too much:

- ◆ Pump may be destroyed due to overheating.
- ◆ Axial thrust too great.

Discharge valve opened too much:

- ◆ Pump can cavitate. Particularly severe with an empty discharge line.
- ◆ Risk of pressure surge.
- ◆ Possible damage to the plain bearings.
- ◆ Magnetic drive may stop.
- ◆ Motor may be overloaded.

Suction valve and discharge valve closed:

- ◆ Destruction due to rapid overheating and sharp rise in pressure.

Control of the pump with the suction valve

- ◆ Cavitation – the volume may only be regulated on the discharge side.

Operation with magnetic drive stopped :

- ◆ If no heat is dissipated, damage to the inner and drive magnet assemblies may occur.

Overrun of the admissible gas content:

- ◆ The flow may stop.
- ◆ Switch pump and vent off for renewed conveyance.
- ◆ Make sure that the gas content is not exceeded, as described in the intended use.

7 Maintenance

7.1 Screw connections of the housing

After initial loading by the operating pressure and operating temperature the tightening torques of all connection screws must be checked at the following points:

- ◆ cover flange
- ◆ housing flange
- ◆ suction flange
- ◆ discharge flange
- ◆ drain flange

See also **Section 6.1.1, para. 1.**

Other inspections are to be performed regularly, depending on the operating requirements.

7.2 Motor

The operating manual of the motor manufacturer must be observed.



A motor with a valid ATEX certificate is to be used if employed in zone 1 and 2.

Observe the ATEX notes of the motor manufacturer.

7.3 Cleaning

Care must be taken when cleaning the pump to ensure that it is not exposed to a strong water jet. The ingress of water into the bearing pedestal will substantially impair bearing lubrication.

7.4 Stand-by pumps

If a pump is on stand-by, it is to be started up from time to time.

This operation is to be performed more often for pumps which are exposed to very strong vibrations from the plant.

When dismantling the pump from the plant, drain it, thoroughly clean it, seal with flange covers and store in accordance with the instructions.

7.5 Notes on dismantling

- ◆ All repair and maintenance work is to be performed by skilled staff using appropriate tools and original spare parts.
- ◆ Is the necessary **documentation** available?
- ◆ Has the pump been taken out of operation, drained and flushed correctly? See also **Section 6.3.**

- ◆ If no new assembly is performed immediately after dismantling, the plastic and ceramic components in particular must be stored carefully.
 - ◆ Richter has the following special tools for dismantling in its range of delivery:
 - ◆ Clamping device Ident. No. 9248-87-1091
 - ◆ Dismantling ring Ident. No. 9247-89-8002
- For instructions on use, see **Sections 10.2 and 10.3.**

7.5.1 Protective clothing



Even if the pump has been properly evacuated and flushed, residue of the medium may still remain in the pump, e.g. between sealing surfaces or in the bearing seats or in the can or the can insert.

Plastic components may absorb medium which gradually emerges from the material after flushing.



Proper protective clothing is to be worn.

Protective clothing is also to be worn even if only the bearing pedestal is to be removed. Medium may penetrated the lantern chamber through the can.

7.5.2 Magnetic fields



Caution ! Strong magnetic fields

Risk during dismantling and in the vicinity of magnetic drives as single parts.

Remove loose parts and other magnetisable metals from the work bench. They could otherwise be attracted: Risk of accident!

Place any tools needed at a safe distance.

Keep electronic equipment and measuring instruments at a distance. In cases of doubt consult the equipment manufacturer.

Hold magnetic drives as single parts firmly or secure. Otherwise they could be attracted, for example, by a vice: Risk of accident!



People with an artificial pacemaker

Keep torso **at a minimum distance of 500 mm.**

For safety's sake, a distance of 150 mm should be observed for watches, electric data carriers, data carriers with magnetic strips etc.

7.6 Dismantling

- Dismantling the complete pump from the plant.
- Undo screwing **901/4** and **554/5** from transition ring / lantern.
- Pull motor **800/1** with transition ring **820** and also hollow drive shaft **216** and drive magnet assembly **858** out of the slide-in unit.



**Caution! Magnetic forces!
Risk of accident !**

Axial forces are produced when the plain bearing pedestal is pulled out of the bearing pedestal. These forces diminish again abruptly after it has been removed.

The operating torque of the magnetic coupling installed is specified on the **type plate**.

- Remove housing screws **901/3, 552/3**.
- Remove lantern **344** with can insert **158/159** and intermediate ring **509/1**.
- Remove cover screws **901/2, 552/1**.
- Remove cover **160**.
- Remove bearing nut **923. Right-hand thread**.
If necessary, hold inner magnet assembly tight with a strap wrench.
- Remove left-hand bearing sleeve **529/1**.
- Remove left-hand bearing bush **545/1**, if damaged.
- Mount clamping device on impeller shaft and engage in the anti-torsion insert. Secure with screws to the housing (see drawing in **Section 10.2**).
- Unscrew inner magnet assembly **859** using a strap wrench.
- Push out ring channels **241/1** and **241/2** as well as the single-piece impeller **230** with the dismantling ring. See drawing in section 10.3.
- The 3 centering gaskets **415/3** are also removed.
- Remove stud **560/1** from the housing.
- If necessary, remove O-ring **412/3** from the inner magnet assembly.
- Remove housing **100**.
- Remove distance ring **504** and right-hand bearing sleeve **529/2** from the impeller shaft.
- Press right-hand bearing bush **545/2** out of the housing.

7.6.1 Can, can insert and intermediate ring

- Loosen the centering of these components at the lateral recesses in the lantern **344**.
- Pull the parts out of the lantern.
- Only separate the can **159** and can insert **158** if one part has to be replaced. If separation is not possible, the unit must be cooled to about 5°C.

With a vacuum-tight design the can insert is glued to the can. Separation is not possible without causing damage.

Dismantling is possible with a can with a leakage monitoring using a flexible p.c. board. However, re-assembly should only be performed at the manufacturer's works.

7.6.2 Dismantling of drive unit

- Undo setscrew **904/1**.
- Separate hollow drive shaft **216** and drive magnet assembly **858** with hex. screws **901/5**, lock washers **934/1**.
- Pull hollow drive shaft **216** off motor shaft.
- Undo hex. screws **901/7** and washers **554/7** and transition ring **820** off the motor flange (possibly use two levers).
- Dismantling can be checked using the sectional drawing in **Section 9.2 and 9.3** and the components available.

7.7 Notes on assembly

- ◆ Use original spare parts. See also **Section 2.4**.
- ◆ Do not use any defective parts.
- ◆ Has the pump been shut down, drained and flushed in accordance with the regulations?
See also **Section 6.3**.
- ◆ Treat close-tolerance areas (not on stainless steel parts) with a corrosion inhibitor. Grease screw thread prior to assembly.
- ◆ The thread in the impeller **230**, the inner magnet assembly **859** and on the pump shaft **211** must not be greased as otherwise no optimum glued connection is possible.
- ◆ Install plain bearings in pairs as supplied or stored.
- ◆ Check whether all parts fit and only then assemble.
- ◆ Important dimensions (centerings, bearing fits or bearing play) are to be checked prior to assembly; perform a trial assembly if required.
- ◆ Many metallic particles adhering to magnetic components such as the inner magnet assembly **859** and drive magnet assembly **858** must be removed prior to assembly. For this purpose simple plasticene can be used..
- ◆ A complete assembly process is described in the following.
Sub-sections can be deduced from this.
- ◆ See also **Section 7.5**.

7.8 Assembly

7.8.1 Assembly of drive unit

- Screw transition ring **820** to the motor **800/1**.
- Screw hollow drive shaft **216** and drive magnet assembly **859** together (**901/5, 934/1**).
- Push hollow drive shaft **216** fully onto motor shaft with key.
- Observe control dimension L, see drawing in **Section 9.2 and 9.3** and pump works certificate.
- Drill the key of the motor shaft for setscrew **904/1**.
- Screw on the setscrew **904/1** and secure with Loctite 243.

7.8.2 Can, can insert and intermediate ring

- Install can insert in the can. If this is not possible, cool the can insert to about +5°C.
- Push intermediate ring **509/1** onto the can **159**.
- Insert the entire unit into the lantern **344**.

7.8.3 Housing, right-hand ring channel and right-hand bearing bush

- Press 3 centering gaskets **415/2** into the housing.
- The bore at the lowest point must not be sealed. Observe nozzle position and drain bore (at lowest point).
- Insert bearing bush **545/1** into the cover **160**.
- Insert bearing bush **545/2** into the housing **100**.
- Press stud **560/1** into the housing **100**.
- Insert right-hand channel ring **241/2** into the housing **100**.

7.8.4 Assembly housing, impeller and inner magnet assembly

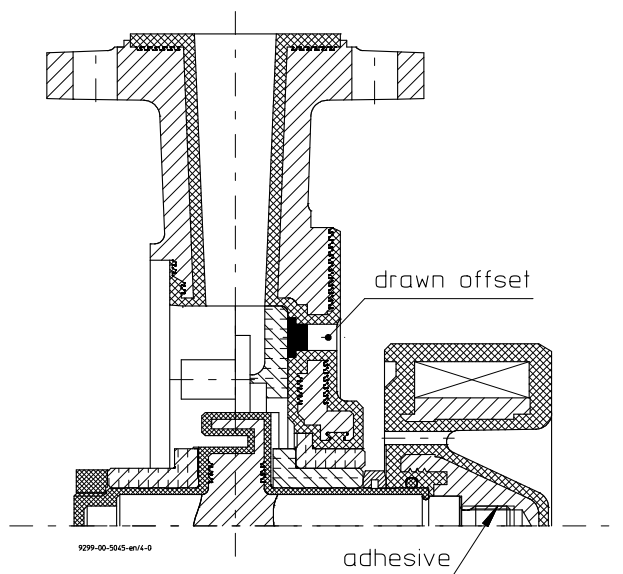

Fig 7

- Mount bearing sleeve **529/2** and distance ring **504** onto the impeller shaft **230** and push this unit through the bearing bush **545/2**. The anti-torsion cams of the bearing sleeve must engage in the grooves.
- Push pre-assembled housing onto the right-hand bearing sleeve **529/2**.
- Apply 1 drop of adhesive to the shaft thread, e.g. Loctite 243 from the company Loctite, or an equivalent.



Only 1 drop of the adhesive should be applied. Otherwise, the next dismantling operation will be more difficult or no longer possible without causing damage.

- Screw inner magnet assembly **859** with O-ring **412/3** onto the impeller shaft **230**. To tighten this unit, use a strap wrench and clamping device if possible (see [Section 10.2](#)). Insert ring channel **241/1** into the housing **100**.
- Mount bearing sleeve **529/1** onto the impeller shaft **230**. The anti-torsion cams must engage in the grooves.
- Tighten bearing nut **923** hand-tight on the impeller shaft.
- Insert cover **160** with bearing bush **545/1** into the housing **100**.
- Tighten cover screws **901/2** with tightening washers **552/1**. For tightening torque, see [Section 1.1](#).
- Check whether the rotating unit can be turned by hand.
- Insert the can **159**, can insert **158** and intermediate ring **509/1** into the lantern **344**.
 - ◆ Observe magnetic forces.
 - ◆ Observe nozzle position.
 - ◆ The drain bore in the housing must be at the lowest position.
- Screw this unit to the previously assembled housing unit using the housing screws **901/3** and the tightening washers **552/3**. For tightening torque, see [Section 1.1](#).

7.8.5 Drain (if provided)

- Insert centering gasket **415/1** into the drain bore of the cover.
- Place blind flange **122** on the centering gasket.
- Screw in studs **901/1** and tighten with washers **554/1** and hex. nuts **920/1**. For tightening torque, see [Section 1.1](#).

7.9 Tests

The pumps are tested with water at the manufacturer's.

The operating data measured are documented in a **works certificate**.

If, during a test after repairs, discrepancies compared with the works certificate are discovered, the following people can be called in:

- 1) In-house pump office
- 2) The manufacturer Richter or its local agent

The following conveying data can be checked using the **pump performance curves** :

- ◆ Flow rate
- ◆ Head
- ◆ Power requirement
- ◆ NPSHR

8 Faults



Faults may result from improper operation. Such improper operation – even brief ones – may cause serious damage to the unit.

In connection with explosion protection, potential sources of ignition (overheating, electrostatic and induced charges, mechanical and electric sparks) can result from these improper operation; their occurrence can only be prevented by adhering to the intended use.

Should there be any uncertainty about the remedy to be applied, please inquire at the in-house pump office or at the pump manufacturer's.

No delivery :

- ◆ Is the pump filled and vented?
- ◆ Is the suction line open, vented, cleaned and correctly laid?
- ◆ Is the discharge line open, vented, cleaned and correctly laid?
- ◆ Is the geodetic head too high?
- ◆ Is air being drawn in?
- ◆ Has the magnetic drive stopped?

Flow rate too high :

- ◆ Is the geodetic head too low?
- ◆ Are the pipe or nozzle resistances too low?
- ◆ Is the pump speed too high or the impeller diameter too large?

Delivery pressure too high :

- ◆ Is the speed too high or the impeller diameter too large?
- ◆ Is the density too high?

Flow rate too low :

- ◆ Have the pump, suction line and discharge line been completely vented, filled and cleaned?
- ◆ Have any strainers installed been cleaned?
- ◆ Are all shut-off devices open?
- ◆ Is the geodetic head too high?
- ◆ Is the NPSHA too low or the NPSHR too high?
- ◆ Are the pipe resistances too high?
- ◆ Is the viscosity too high?
- ◆ Is the direction of rotation correct?
- ◆ Is the speed too low or the impeller diameter too small?
- ◆ Are pump parts worn?
- ◆ Gas in the medium?

Delivery pressure too high :

- ◆ Is the speed too high or the impeller diameter too large?
- ◆ Is the density too high?

Motor consumes too much electricity :

- ◆ Is the flow rate, density or viscosity too high?
- ◆ Is the speed too high or the impeller diameter too large?
- ◆ Can the pump shaft be turned properly?

Pump does not run smoothly or creates noises :

- ◆ Are the rolling bearings of the motor damaged?
- ◆ Are parts of the hydraulics damaged?
- ◆ Is the flow rate too low or too high?
- ◆ Is the impeller balanced?
- ◆ Is the pump twisted?
- ◆ Is there foreign matter in the pump?

Leak from the pump :

- ◆ Are all screws tightened to the correct tightening torque?
- ◆ Were the sealing surfaces assembled in a clean state?
- ◆ Have approved gaskets been installed?

9 Sectional drawing

9.1 Legend sectional drawing

100	housing	554/x	washer
122	blind cover	557/1	contact disc
158	can insert	560/1	stud
159	can	592	support (upwards and IEC motor size 132)
160	cover	800/1	motor
216	hollow drive shaft	820	transition ring (dispensed with IEC motor sizes 100 + 112)
235	impeller shaft	858	drive magnet assembly
241/x	ring channel	859	inner magnet assembly
344	lantern	900/1	ring bolt
412/3	o-ring	901/x	hex. screw
415/x	centering gasket	902/1	stud screw
504	distance ring	904/1	setscrew
509/1	intermediate ring	914/2	hex. socket screw
529/x	bearing sleeve	920/1	hex. nut
545/x	bearing bush	923	bearing nut
552/x	tightening washer	934/1	lock washer
		936/2	toothed lock washer

9.2 Sectional drawing MPB, housing in L-position

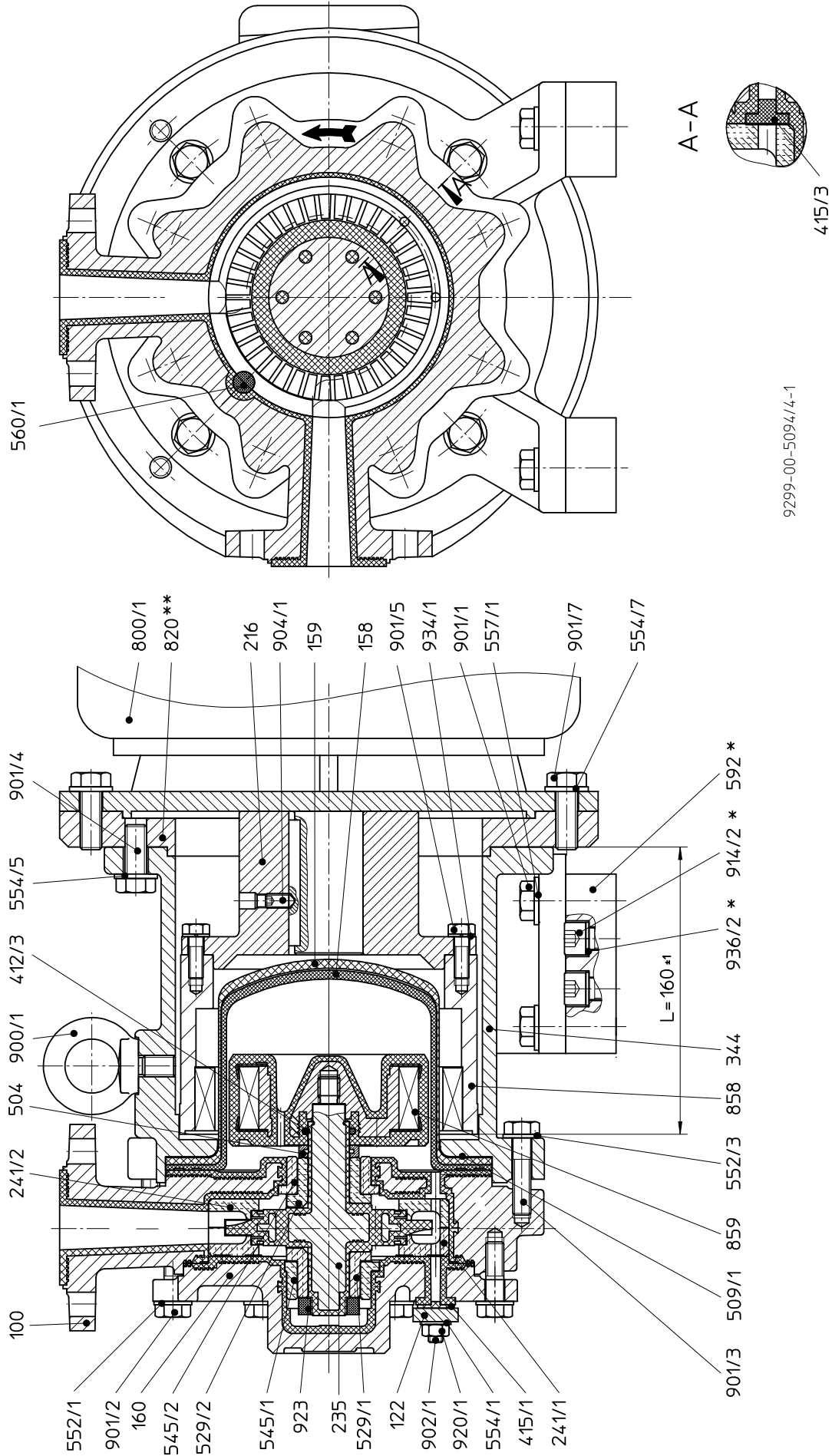

Drill key for motor shaft during assembly.
Secure setscrew **904/1** with Loctite 243.

Clearances **X**, **Y** and **Z** see pump work's certificate

* Base required for IEC motor sizes 132 and upwards

** Transition ring dispensed with IEC motor sizes 100 and 112

9.3 Sectional drawing MPB, housing in V-position

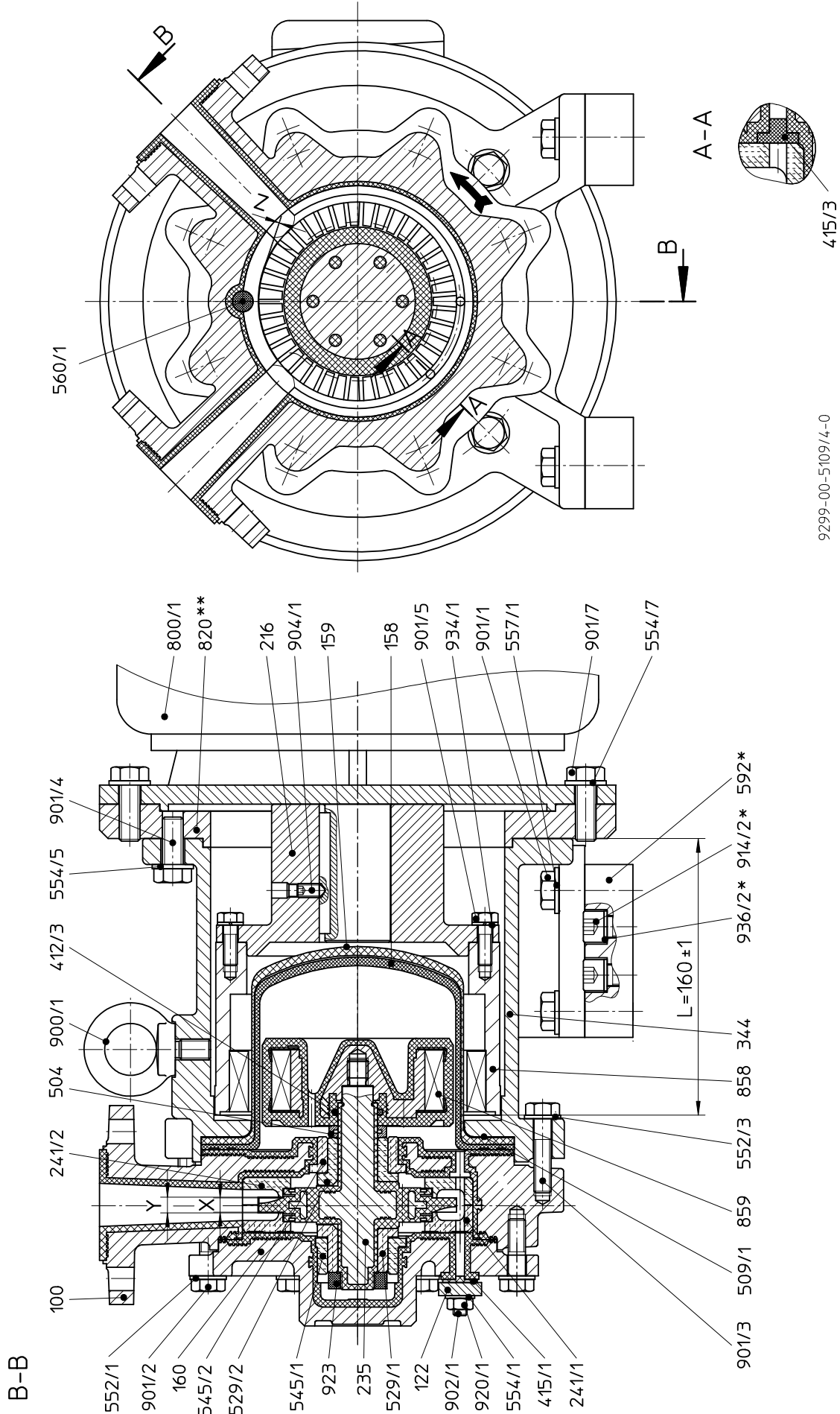

Drill key for motor shaft during assembly.
Secure setscrew **904/1** with Loctite 243.

Clearances **X**, **Y** and **Z** see pump work's certificate
* Base required for IEC motor sizes 132 and upwards
** Transition ring dispensed with IEC motor sizes 100 and 112

10 Assembly aids

10.1 Boring template

Pump size

MPB 25-25-115

Ident.-No

9217-89-1094

Collar bore bush
DIN 172-A 5x8

Blind flange
9218-83-1038

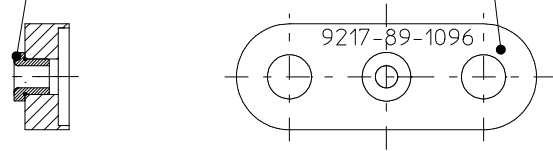

9299-07-0000en/4-0

10.2 Assembly/Dismantling aid for inner magnet assembly

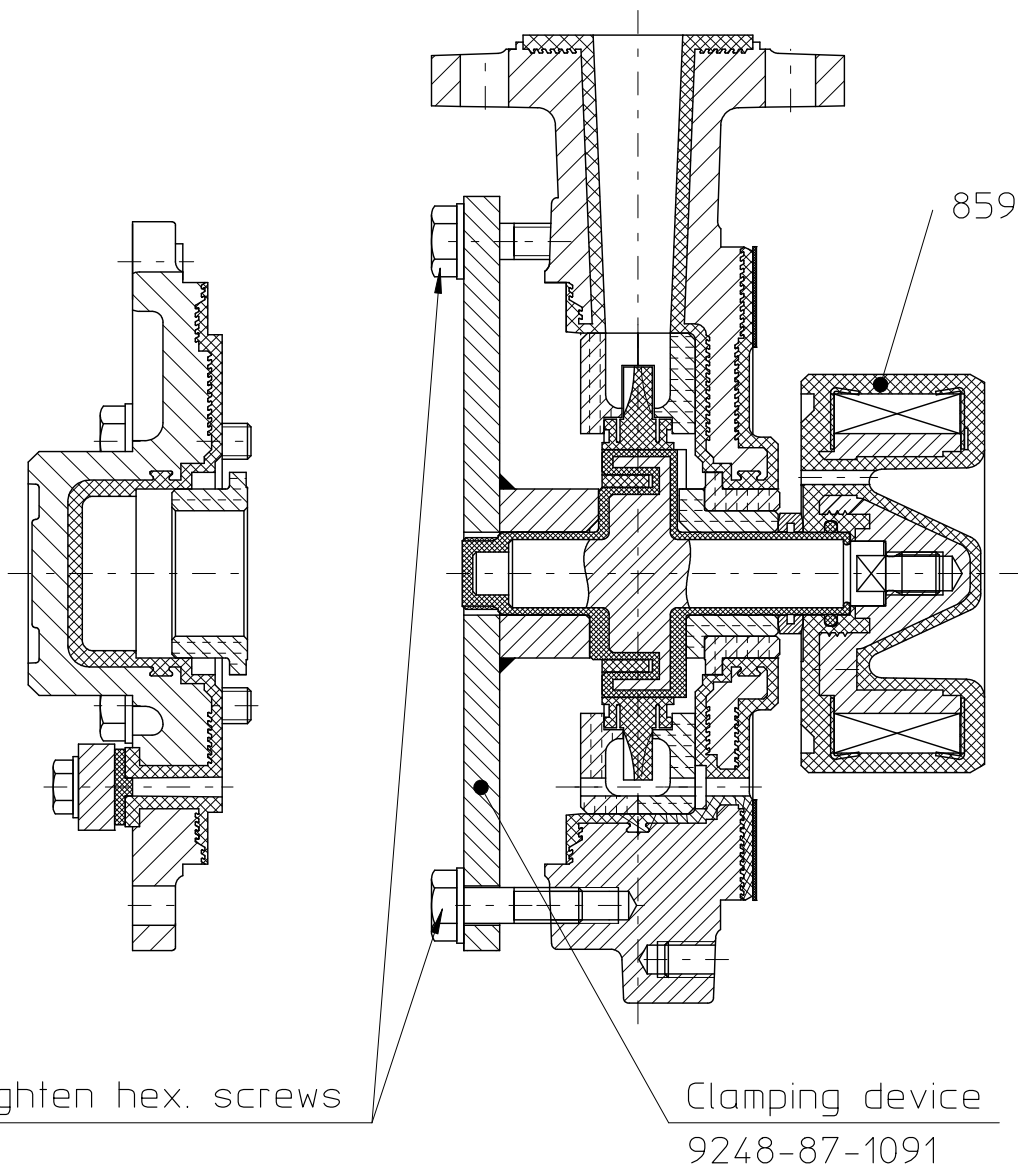

859 Inner magnet assembly:

Tighten and loosen the inner magnet assembly
with a strap wrench

9299-00-5151_en/4-0

10.3 Dismantling ring

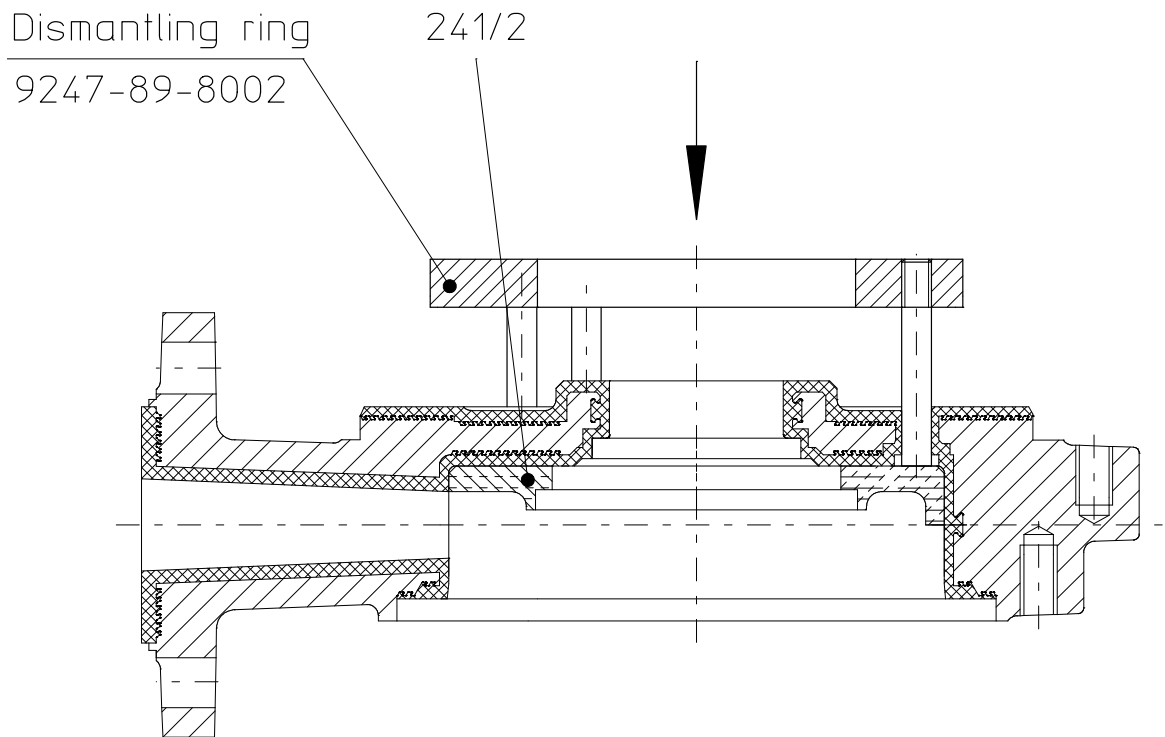

241/2 Ring channel

Push out the right-hand ring channel evenly by hand with the dismantling ring

9299-00-5063_en/4-0

Baureihe/Series/Série Ausführung **Peripheralpumpe**

MPB

Design **Peripheral pump**



Construction **Pompe périphériques**

Einsatzgrenzen / operating limits

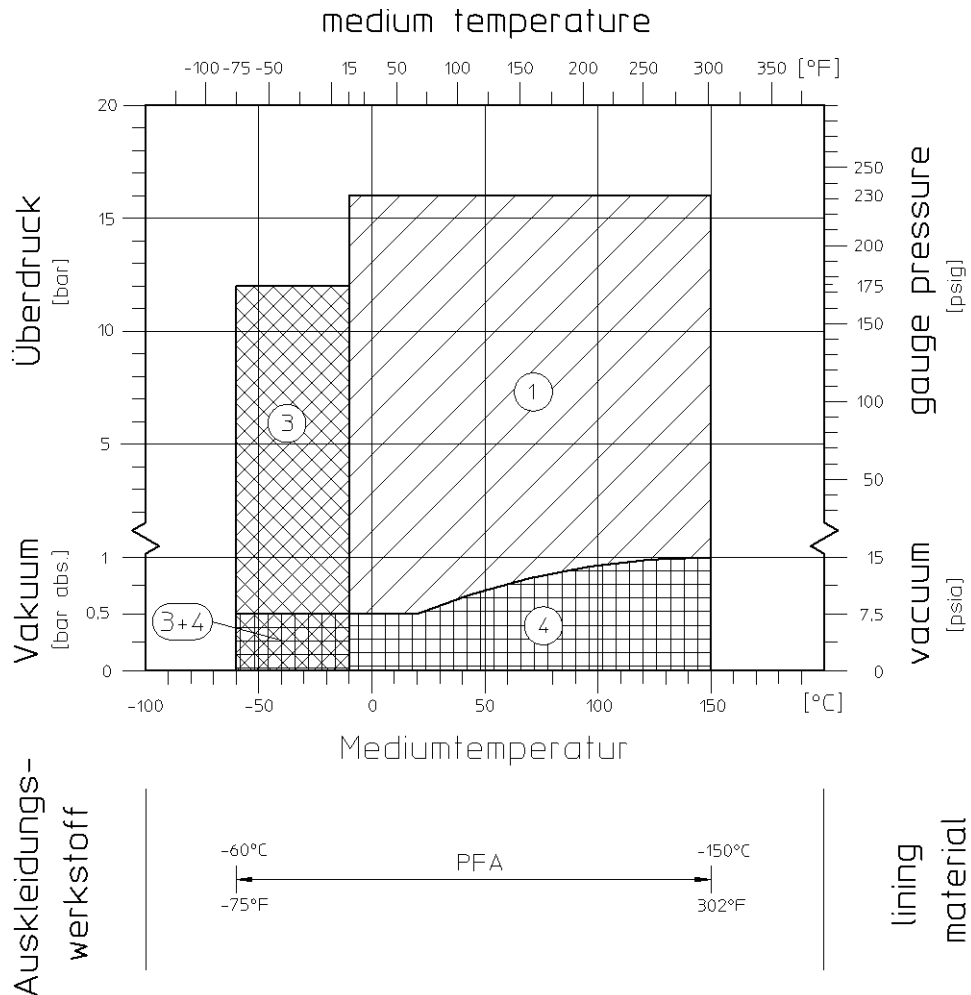

- | | |
|---|---|
| <p>1 Standard
Bei Einsatz unter ASME-Bedingungen (Sphäroguss nach A395) kann der Standardbereich auf -30 °C und 16 bar erweitert werden.</p> <p>3 Tiefere Temperaturen durch Sondermaterial</p> <p>4 Höheres Vakuum bei Pumpenstillstand durch Sonderspalttöpfe</p> | <p>Standard
Application under ASME-specification (ductile iron acc. to A395) the standard range can be expanded up to -30 °C and 16 bar.</p> <p>Lower temperatures by special materials</p> <p>Higher vacuum at pump standstill by special can unit</p> |
|---|---|

Modification techniques possibles sans réservations!
 Graphique non à l'échelle!
 Dimensions variables uniquement revêtues d'une signature!

This leaflet is subject to alteration!
 Drawing not to scale!
 Certified for construction purposes only when signed!

Technische Änderungen vorbehalten!
 Nicht maßstäblich!
 Maße nur mit Unterschrift verbindlich!

CE Konformitätserklärung nach EN ISO//IEC 17050
Declaration of Conformity according to EN ISO//IEC 17050

Produkt Magnetkupplungs-Chemiekreiselpumpe
 freies Wellenende, Blockausführung oder als Aggregat¹⁾
 Product *Magnetic Drive Chemical Centrifugal Pump*
Bare shaft, block version or as unit¹⁾

Baureihe MNK, MNK-B, MNK-X, MNK-XB, MNK-S, MNK-SB, MNKA, MNKA-B
 Series MPB, MDK, MDK-B, RMA, RMA-B, RMI, RMI-B

EU-Richtlinien 2006/42/EG Maschinenrichtlinie *Machinery Directive*
 EU-Directive 94/9/EG Explosionsschutzrichtlinie ATEX *Equipment explosive atmosphere*

Modul Interne Fertigungskontrolle
Production Quality Assurance

Angewandte EN 14121
 harmonisierte Normen EN 809
 Applied harmonised EN 13463-1
 Standards

Kennzeichnung 2006/42/EG
 Marking 94/9/EG



Die technische Dokumentation nach Richtlinie 94/9EG ist bei der u.a. benannten Stelle hinterlegt.
The technical documentation is filed by below mentioned notified body according to directive 94/9/EC.
 Physikalische-Technische Bundesanstalt (PTB), D-38116 Braunschweig

Baureihe Series	Registrier-Nr. Registered #	Baureihe Series	Registrier-Nr. Registered #	Baureihe Series	Registrier-Nr. Registered #
MNK	02ATEXD032	MNKA	04ATEXD007	RMA	09ATEXD062
MNK-B	03ATEXD006	MNKA-B		RMA-B	09ATEXD062
MNK-X	02ATEXD032	MPB	03ATEXD068	RMI	
MNKXB	03ATEXD006	MDK	02ATEXD009	RMI-B	
MNK-S	02ATEXD032	MDK-B	03ATEXD008		
MNK-SB	03ATEXD006				

Das Unternehmen Richter Chemie-Technik GmbH bescheinigt hiermit, dass die o.a. Baureihen die grundsätzlichen Anforderungen der aufgeführten Richtlinien und Normen erfüllt.
Richter Chemie-Technik GmbH confirms that the basic requirements of the above specified directives and standards have been fulfilled.

Bevollmächtigt für die Zusammenstellung der technischen Unterlagen nach 2006/42/EG: A. Linges
Authorised person compiled the technical files according to 2006/42/EG:

1) Gilt nicht für das Aggregat nach 94/9/EG (ATEX Leitfaden Juni 2009 Abschn. 3.7.5 2.a)
 1) *Not valid for the unit according to 94/9/EG (ATEX Guideline June 2009 Paragraph 3.7.5 2.a)*

Kempen, 01.03.2010



G. Kleining
 Leiter Forschung & Entwicklung
 Manager Research & Development



A. Linges
 Leiter Qualitätsmanagement
 Quality Manager

CE Konformitätserklärung nach EN ISO//IEC 17050
Declaration of Conformity according to EN ISO//IEC 17050

Produkt <i>Product</i>	Magnetkupplungs-Chemiekreiselpumpe als Aggregat <i>Magnetic Drive Chemical Centrifugal Pump as unit</i>
Baureihe <i>Series</i>	MNK, MNK-B, MNK-X, MNK-XB, MNK-S, MNK-SB, MNKA, MNKA-B MPB, MDK, MDK-B, RMA, RMA-B, RMI, RMI-B
EU-Richtlinien <i>EU-Directive</i>	2006/42/EG Maschinenrichtlinie <i>Machinery Directive</i>
Modul	Interne Fertigungskontrolle <i>Production Quality Assurance</i>
Angewandte harmonisierte Normen <i>Applied harmonised Standards</i>	EN 14121 EN 809
Kennzeichnung <i>Marking</i>	2006/42/EG CE

Das Unternehmen Richter Chemie-Technik GmbH bescheinigt hiermit, dass die o.a. Baureihen die grundsätzlichen Anforderungen der aufgeführten Richtlinien und Normen erfüllt.
Richter Chemie-Technik GmbH confirms that the basic requirements of the above specified directives and standards have been fulfilled.

Bevollmächtigt für die Zusammenstellung der technischen Unterlagen nach 2006/42/EG:
Authorised person compiled the technical files according to 2006/42/EG:

A. Linges

Kempen, 01.07.2010



G. Kleining
Leiter Forschung & Entwicklung
Manager Research & Development

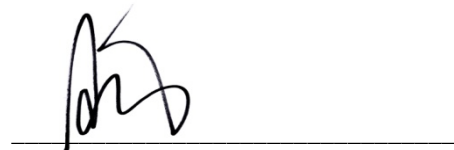

A. Linges
Leiter Qualitätsmanagement
Quality Manager

Safety Information / **Declaration of No Objection** Concerning the Contamination of Richter-Pumps, -Valves and Components

1 SCOPE AND PURPOSE

Each entrepreneur (operator) carries the responsibility for the health and safety of his employees. This extends also to the personnel, who implements repairs with the operator or with the contractor.

Enclosed declaration is for the information of the contractor concerning the possible contamination of the pumps, valves and component sent in for repair. On the basis of this information for the contractor is it possible to meet the necessary preventive action during the execution of the repair.

Note: The same regulations apply to repairs **on-site**.

2 PREPARATION OF DISPATCH

Before the dispatch of the aggregates the operator must fill in the following declaration completely and attach it to the shipping documents. The shipping instructions indicated in the respective manual are to be considered, for example:

- Discharge of operational liquids
- remove filter inserts
- lock all openings hermetically
- proper packing
- Dispatch in suitable transport container
- Declaration of the contamination fixed **outside!!** on the packing

Declaration about the Contamination of Richter Pumps, -Valves and Components

The repair and/or maintenance of pumps, valves and components can only be implemented if a completely filled out declaration is available. If this is not the case, delay of the work will occur. If this declaration is not attached to the devices, which have to be repaired, the transmission can be rejected.

Every aggregate has to have it's own declaration.

This declaration may be filled out and signed only by authorized technical personnel of the operator.

Contractor/dep./institute : _____ Street : _____ Postcode, city: _____ Contact person: _____ Phone : _____ Fax : _____ End user : _____	Reason for transmitting <input checked="" type="checkbox"/> Please mark the applicable Repair: <input type="checkbox"/> subject to fee <input type="checkbox"/> Warranty Exchange: <input type="checkbox"/> subject to fee <input type="checkbox"/> Warranty <input type="checkbox"/> Exchange/ Replacement already initiated/received Return: <input type="checkbox"/> Leasing <input type="checkbox"/> Loan <input type="checkbox"/> for credit note																																												
A. Details of Richter-product:																																													
Classification: _____ Article number: _____ Serial number: _____	Failure description: _____ Equipment: _____ Application tool: _____ Application process: _____																																												
B. Condition of the Richter-product:																																													
<table border="1" style="width:100%; border-collapse: collapse;"> <thead> <tr> <th style="width:30%;"></th> <th style="width:10%; text-align: center;">no¹⁾</th> <th style="width:10%; text-align: center;">yes</th> <th style="width:10%; text-align: center;">no</th> </tr> </thead> <tbody> <tr> <td>Was it in operation ?</td> <td style="text-align: center;"><input type="checkbox"/></td> <td style="text-align: center;"><input type="checkbox"/></td> <td style="text-align: center;"><input checked="" type="checkbox"/></td> </tr> <tr> <td>Drained (product/operating supply item) ?</td> <td style="text-align: center;"><input checked="" type="checkbox"/></td> <td style="text-align: center;"><input type="checkbox"/></td> <td style="text-align: center;"><input type="checkbox"/></td> </tr> <tr> <td>All openings hermetically locked!</td> <td style="text-align: center;"><input checked="" type="checkbox"/></td> <td style="text-align: center;"><input type="checkbox"/></td> <td style="text-align: center;"><input type="checkbox"/></td> </tr> <tr> <td>Cleaned ?</td> <td style="text-align: center;"><input checked="" type="checkbox"/></td> <td style="text-align: center;"><input type="checkbox"/></td> <td style="text-align: center;"><input type="checkbox"/></td> </tr> </tbody> </table>		no ¹⁾	yes	no	Was it in operation ?	<input type="checkbox"/>	<input type="checkbox"/>	<input checked="" type="checkbox"/>	Drained (product/operating supply item) ?	<input checked="" type="checkbox"/>	<input type="checkbox"/>	<input type="checkbox"/>	All openings hermetically locked!	<input checked="" type="checkbox"/>	<input type="checkbox"/>	<input type="checkbox"/>	Cleaned ?	<input checked="" type="checkbox"/>	<input type="checkbox"/>	<input type="checkbox"/>	<table border="1" style="width:100%; border-collapse: collapse;"> <thead> <tr> <th style="width:60%;"></th> <th style="width:10%; text-align: center;">no¹⁾</th> <th style="width:10%; text-align: center;">yes</th> </tr> </thead> <tbody> <tr> <td>Contamination : toxic</td> <td style="text-align: center;"><input type="checkbox"/></td> <td style="text-align: center;"><input type="checkbox"/></td> </tr> <tr> <td>caustic</td> <td style="text-align: center;"><input type="checkbox"/></td> <td style="text-align: center;"><input type="checkbox"/></td> </tr> <tr> <td>inflammable</td> <td style="text-align: center;"><input type="checkbox"/></td> <td style="text-align: center;"><input type="checkbox"/></td> </tr> <tr> <td>explosive²⁾</td> <td style="text-align: center;"><input type="checkbox"/></td> <td style="text-align: center;"><input type="checkbox"/></td> </tr> <tr> <td>mikrobiological²⁾</td> <td style="text-align: center;"><input type="checkbox"/></td> <td style="text-align: center;"><input type="checkbox"/></td> </tr> <tr> <td>radioactive³⁾</td> <td style="text-align: center;"><input type="checkbox"/></td> <td style="text-align: center;"><input type="checkbox"/></td> </tr> <tr> <td>other pollutant</td> <td style="text-align: center;"><input type="checkbox"/></td> <td style="text-align: center;"><input type="checkbox"/></td> </tr> </tbody> </table>		no ¹⁾	yes	Contamination : toxic	<input type="checkbox"/>	<input type="checkbox"/>	caustic	<input type="checkbox"/>	<input type="checkbox"/>	inflammable	<input type="checkbox"/>	<input type="checkbox"/>	explosive ²⁾	<input type="checkbox"/>	<input type="checkbox"/>	mikrobiological ²⁾	<input type="checkbox"/>	<input type="checkbox"/>	radioactive ³⁾	<input type="checkbox"/>	<input type="checkbox"/>	other pollutant	<input type="checkbox"/>	<input type="checkbox"/>
	no ¹⁾	yes	no																																										
Was it in operation ?	<input type="checkbox"/>	<input type="checkbox"/>	<input checked="" type="checkbox"/>																																										
Drained (product/operating supply item) ?	<input checked="" type="checkbox"/>	<input type="checkbox"/>	<input type="checkbox"/>																																										
All openings hermetically locked!	<input checked="" type="checkbox"/>	<input type="checkbox"/>	<input type="checkbox"/>																																										
Cleaned ?	<input checked="" type="checkbox"/>	<input type="checkbox"/>	<input type="checkbox"/>																																										
	no ¹⁾	yes																																											
Contamination : toxic	<input type="checkbox"/>	<input type="checkbox"/>																																											
caustic	<input type="checkbox"/>	<input type="checkbox"/>																																											
inflammable	<input type="checkbox"/>	<input type="checkbox"/>																																											
explosive ²⁾	<input type="checkbox"/>	<input type="checkbox"/>																																											
mikrobiological ²⁾	<input type="checkbox"/>	<input type="checkbox"/>																																											
radioactive ³⁾	<input type="checkbox"/>	<input type="checkbox"/>																																											
other pollutant	<input type="checkbox"/>	<input type="checkbox"/>																																											
If yes, with which cleaning agent: _____ and with which cleaning method: _____																																													
¹⁾ if "no", then forward to D. ← ²⁾ Aggregates, which are contaminated with microbiological or explosive substances, are only accepted with documented evidence of an approved cleaning. ³⁾ Aggregates, which are contaminated with radioactive substances, are not accepted in principle.																																													
C. Details of the discharged materials (must be filled out imperatively)																																													
1. With which materials did the aggregate come into contact ? Trade name and/or chemical designation of operational funds and discharged materials, material properties, e.g. as per safety data sheet (e.g. toxic, inflammable, caustic)																																													
<table border="1" style="width:100%; border-collapse: collapse;"> <thead> <tr> <th style="width:30%;"></th> <th style="width:30%; text-align: center;">no</th> <th style="width:30%; text-align: center;">yes</th> </tr> </thead> <tbody> <tr> <td>X Trade name: _____ Chemical designation: _____</td> <td style="text-align: center;"><input type="checkbox"/></td> <td style="text-align: center;"><input type="checkbox"/></td> </tr> <tr> <td>a) _____</td> <td style="text-align: center;"><input type="checkbox"/></td> <td style="text-align: center;"><input type="checkbox"/></td> </tr> <tr> <td>b) _____</td> <td style="text-align: center;"><input type="checkbox"/></td> <td style="text-align: center;"><input type="checkbox"/></td> </tr> <tr> <td>c) _____</td> <td style="text-align: center;"><input type="checkbox"/></td> <td style="text-align: center;"><input type="checkbox"/></td> </tr> <tr> <td>d) _____</td> <td style="text-align: center;"><input type="checkbox"/></td> <td style="text-align: center;"><input type="checkbox"/></td> </tr> </tbody> </table>			no	yes	X Trade name: _____ Chemical designation: _____	<input type="checkbox"/>	<input type="checkbox"/>	a) _____	<input type="checkbox"/>	<input type="checkbox"/>	b) _____	<input type="checkbox"/>	<input type="checkbox"/>	c) _____	<input type="checkbox"/>	<input type="checkbox"/>	d) _____	<input type="checkbox"/>	<input type="checkbox"/>																										
	no	yes																																											
X Trade name: _____ Chemical designation: _____	<input type="checkbox"/>	<input type="checkbox"/>																																											
a) _____	<input type="checkbox"/>	<input type="checkbox"/>																																											
b) _____	<input type="checkbox"/>	<input type="checkbox"/>																																											
c) _____	<input type="checkbox"/>	<input type="checkbox"/>																																											
d) _____	<input type="checkbox"/>	<input type="checkbox"/>																																											
2. Are the materials specified above harmful to health ? ←																																													
3. Dangerous decomposition products during thermal load ? ← If yes, which ones ?																																													

D. Mandatory declaration: We assure that the data in this explanation are truthful and complete and as a signatory I am able to form an opinion about this. We are aware that we are responsible towards the contractor for damages, which results from incomplete and incorrect data. We commit ourselves to exempt the contractor from claims for damages of thirds resulting from incomplete or incorrect data. We are aware that we are directly responsible towards thirds, irrespective of this declaration, which belongs in particularly to the employees of the contractor consigned with the handling repair of the product.

Name of the authorized person (in block letters): _____

_____ Date

_____ Signature

Company stamp

FAX**Fax No. ()****Pages (incl. cover sheet) ()****To:**

()

Richter Chemie-Technik GmbH
Otto-Schott-Straße 2
D-47906 KempenTelefon +49 (0) 21 52/146-0
Telefax +49 (0) 21 52/146-190richter-info@richter-ct.com
www.richter-ct.comContact person:
()Reference:
()Extension:
- ()E-Mail Address:
()Date:
()**Your order No.:** ()**Our Kom. No.:** ()**Serial No.:** ()

Dear Sirs,

The compliance with laws for the industrial safety obligates all commercial enterprises to protect their employees and/or humans and environment against harmful effects while handling dangerous materials.

The laws are such as: the Health and Safety at Work Act (ArbStättV), the Ordinance on Harzadous Substances (GefStoffV, BIOSTOFFV), the procedures for the prevention of accidents as well as regulations to environmental protection, e.g. the Waste Management Law (AbfG) and the Water Resources Act (WHG)

An inspection/repair of Richter products and parts will only take place, if the attached explanation is filled out correctly and completely by authorized and qualified technical personnel and is available.

In principle, radioactively loaded devices sent in, are not accepted.

Despite careful draining and cleaning of the devices, safety precautions should be necessary however, the essential information must be given.

The enclosed declaration of no objection is part of the inspection/repair order. Even if this certificate is available, we reserve the right to reject the acceptance of this order for other reasons.

Best regards
RICHTER CHEMIE-TECHNIK GMBHEnclosures

()