

Baureihe/Series/Série

Ausführung **Magnetkupplungspumpe ASME
Blockbauweise**

MNKA-B

Design **Magnet drive pump ASME
Close-coupled design**



Construction **Pompe à entraînement magnétique ASME
Construction monobloc**

**Aufstellungsplan mit NEMA-Motoren
Outline drawing with NEMA-motor
Cotes d' encombrement avec NEMA-moteur**

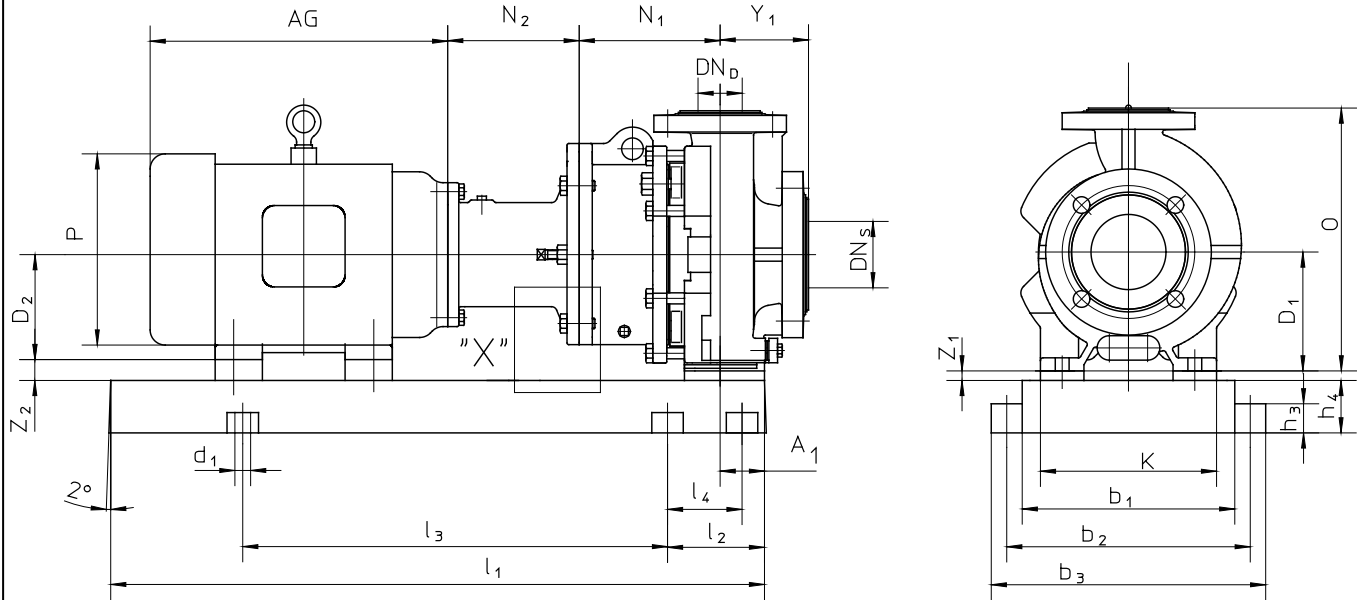

Einzelheit "X"
Detail "X"
Detail "X"

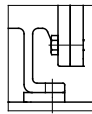

Adapter Motor 140TC
adapter motor 140TC
adaptateur moteur 140TC

Pumpengröße Pump size Taille de pompe	DN _S [inch] (mm)	DN _D [inch] (mm)	A ₁ [inch] (mm)	D ₁ [inch] (mm)	K [inch] (mm)	N ₁ [inch] (mm)	O [inch] (mm)	Y [inch] (mm)
1.5"x1"x6"	1.5 (40)	1 (25)	1.97 (50)	5.25 (133,4)	7.97 (202,4)	6.34 (161)	11.75 (298,5)	4 (101,6)
3"x2"x6"	3 (80)	2 (50)						
1.5"x1"x8"	1.5 (40)	1 (25)		8.25 (209,6)	11.88 (301,8)	8.19 (208)	16.75 (425,5)	
3"x1.5"x8"	3 (80)	1.5 (40)						
2"x1"x10"	2 (50)	1 (25)						

Modification techniques sans préavis, réservées!
Graphique non à l'échelle!
Dimensions variables uniquement revêtues d'une signature!

This leaflet is subject to alteration!
Drawing not to scale!
Certified for construction purposes only when signed!

Technische Änderungen vorbehalten!
Nicht maßstäblich!
Maße nur mit Unterschrift verbindlich!

Baureihe/Series/Série

Ausführung

**Magnetkupplungspumpe ASME
Blockbauweise**

MNKA-B

Design

**Magnet drive pump ASME
Close-coupled design**



Construction

**Pompe à entraînement magnétique ASME
Construction monobloc**

Modification techniques sans préavis, réservées!
 Graphique non à l'échelle!
 Dimensions variables uniquement revêtues d'une signature!

Grundplattengröße Base plate size Taille du socle	[inch] (mm)	b ₁ [inch] (mm)	b ₂ [inch] (mm)	b ₃ [inch] (mm)	d ₁ [inch] (mm)	h ₃ [inch] (mm)	h ₄ [inch] (mm)	l ₁ [inch] (mm)	l ₂ [inch] (mm)	l ₃ [inch] (mm)	l ₄ [inch] (mm)	kg
2 = 10.63 x 19.69 (270 x 500)		10.63 (270)	12.59 (320)	14.17 (360)	0.75 (19)	1.18 (30)	1.18 (30)	19.69 (500)	3.54 (90)	12.6 (320)	-	16
3 = 11.81 x 35.43 (300 x 900)		11.81 (300)	13.78 (350)	15.35 (390)		1.38 (35)	2.56 (65)	35.43 (900)	5.9 (150)	23.62 (600)	3.54 (90)	37
4 = 13.84 x 39.37 (340 x 1000)		13.84 (340)	15.75 (400)	17.72 (450)	0.95 (24)	1.57 (40)	3.15 (80)	39.37 (1000)	6.69 (170)	25.98 (660)	4.33 (110)	55
5 = 14.96 x 44.09 (380 x 1120)		14.96 (380)	17.32 (440)	19.29 (490)				44.09 (1220)	7.48 (190)	29.13 (740)	5.12 (130)	72

This leaflet is subject to alteration!
 Drawing not to scale!
 Certified for construction purposes only when signed!

	Pumpe pump pompe	Adapter adapter adaptateur	Motor motor moteur	Grundplatte base plate socle	Σ
Maße dimensions dimensions	Z ₁		Z ₂		L
Gewichte weights poids	kg	kg	kg	kg	kg

Technische Änderungen vorbehalten!
 Nicht maßstäblich!
 Maße nur mit Unterschrift verbindlich!

Pumpengröße Pump size Taille de pompe	Motorbaugröße / motor size / taille de moteur											
	143 TC	145 TC	182 TC	184 TC	213 TC	215 TC	254 TC	256 TC	284 TSC	286 TSC	324 TSC	326 TSC
1.5"x1"x6"	2				3			4				5
3"x2"x6"												
1.5"x1"x8"												
3"x1.5"x8"												
2"x1"x10"												

Baureihe/Series/Série

Ausführung

**Magnetkupplungspumpe ASME
Blockbauweise**

MNKA-B

Design

**Magnet drive pump ASME
Close-coupled design**

Construction

**Pompe à entraînement magnétique ASME
Construction monobloc**



Modification techniques sans préavis, réservées!
 Graphique non à l'échelle!
 Dimensions variables uniquement revêtues d'une signature!

This leaflet is subject to alteration!
 Drawing not to scale!
 Certified for construction purposes only when signed!

Technische Änderungen vorbehalten!
 Nicht maßstäblich!
 Maße nur mit Unterschrift verbindlich!

Motorabmessung
Motor dimension
Dimensions moteur

NEMA-Motor NEMA-motor NEMA-moteur	D₂ [inch] ([mm])	AG [inch] ([mm])	P [inch] ([mm])
140 TC *	3,5 (88,9)	14.37 (365)	7.28 (185)
180 TC	4.5 (114,3)	13.77 (350)	9.25 (235)
210 TC	5.25 (133,4)	16.88 (429)	10.51 (267)
250 TC	6.25 (158,8)	21.3 (541)	13.22 (336)
280 TSC	7 (177,8)	23.07 (586)	14.88 (378)
320 TSC	8 (203,2)	25.43 (646)	17 (432)

* mit Stützfuß
* with support bracket
* avec patte de support

Adapterabmessung
Adapter dimension
Dimensions adaptateur

NEMA-Motor NEMA-motor NEMA-moteur	N₂ [inch] ([mm])	
140 TC *	4.44 (112,7)	Gruppe 1/ group 1/ groupe 1
180 TC	6.28 (159,5)	
210 TC		
250 TC		
280 TSC		
180 TC	6.57 (167)	Gruppe 2/ group 2/ groupe 2
210 TC		
250 TC		
280 TSC		
320 TSC	6.34 (161)	