

Baureihe/Series/Série

Ausführung **Magnetkupplungspumpe ASME**

MNKA

Design **Magnet drive pump ASME**



Construction **Pompe à entraînement magnétique ASME**

Aufstellungsplan mit NEMA-Motoren
Outline drawing with NEMA-motor
Cotes d' encombrement avec NEMA-moteur

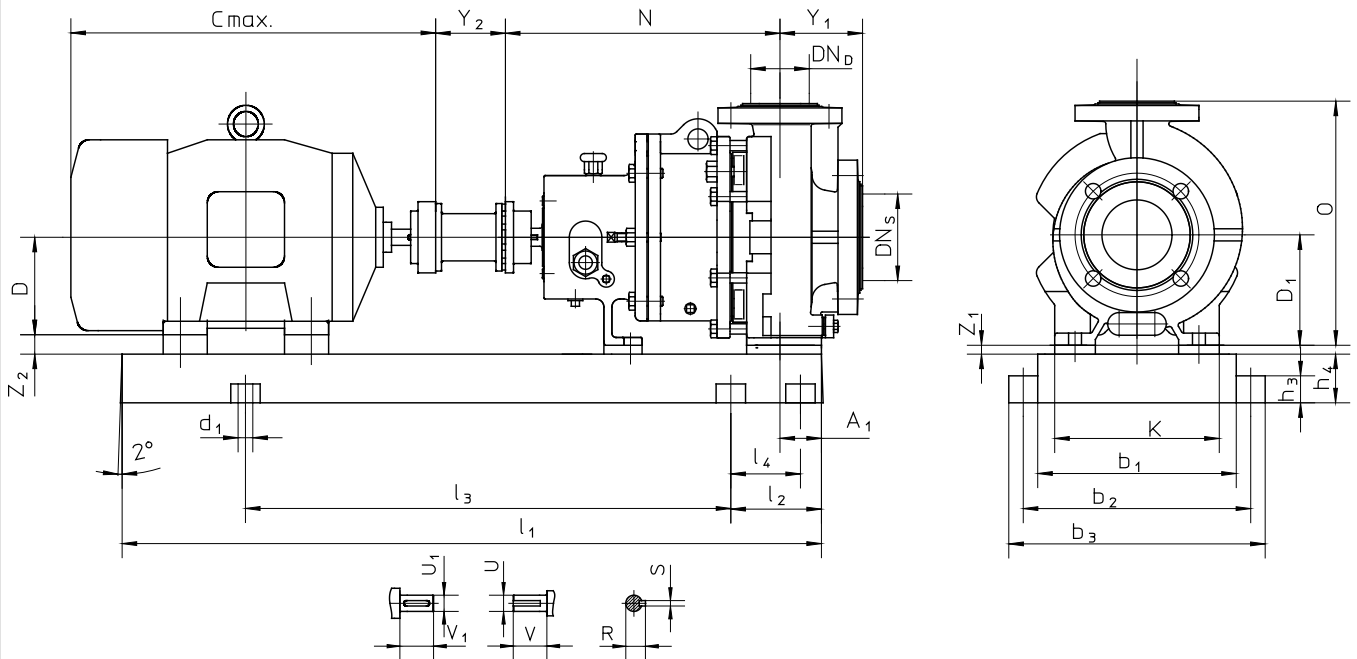

Pumpengröße Pump size Taille de pompe	DN _S [inch] [mm]	DN _D [inch] [mm]	A ₁ [inch] [mm]	D ₁ [inch] [mm]	K [inch] [mm]	N [inch] [mm]	O [inch] [mm]	R [inch] [mm]	S [inch] [mm]	U [inch] [mm]	V [inch] [mm]	Y ₁ [inch] [mm]
1.5"x1"x6"	1.5 (40)	1 (25)	1.97 (50)	5.25 (133,4)	7.97 (202,4)	13.5 (342,9)	11.75 (298,5)	0.96 (24,3)	0.19 (4,8)	0.87 (22,2)	2 (50,8)	4 (101,6)
3"x2"x6"	3 (80)	2 (50)										
1.5"x1"x8"	1.5 (40)	1 (25)		8.25 (209,6)	11.88 (301,8)	19.5 (495,3)	16.75 (425,5)	1.23 (31,4)	0.25 (6,35)	1.13 (28,6)	2.63 (66,7)	
3"x1.5"x8"	3 (80)	1.5 (40)										
2"x1"x10"	2 (50)	1 (25)										

Modification techniques sans préavis, réservées!
 Graphique non à l'échelle!
 Dimensions variables uniquement revêtues d'une signature!

This leaflet is subject to alteration!
 Drawing not to scale!
 Certified for construction purposes only when signed!

Technische Änderungen vorbehalten!
 Nicht maßstäblich!
 Maße nur mit Unterschrift verbindlich!

Baureihe/Series/Série Ausführung **Magnetkupplungspumpe ASME**

MNKA

Design **Magnet drive pump ASME**



Construction **Pompe à entraînement magnétique ASME**

Modification techniques sans préavis, réservées!
 Graphique non à l'échelle!
 Dimensions variables uniquement revêtues d'une signature!

This leaflet is subject to alteration!
 Drawing not to scale!
 Certified for construction purposes only when signed!

Technische Änderungen vorbehalten!
 Nicht maßstäblich!
 Maße nur mit Unterschrift verbindlich!

Grundplattengröße Base plate size Taille du socle	[inch] [mm]	b ₁ [inch] [mm]	b ₂ [inch] [mm]	b ₃ [inch] [mm]	d ₁ [inch] [mm]	h ₃ [inch] [mm]	h ₄ [inch] [mm]	l ₁ [inch] [mm]	l ₂ [inch] [mm]	l ₃ [inch] [mm]	l ₄ [inch] [mm]	kg
3 =	11.81 x 35.43 (300 x 900)	11.81 (300)	13.78 (350)	15.35 (390)	0.75 (19)	1.38 (35)	2.56 (65)	35.43 (900)	5.9 (150)	23.62 (600)	3.54 (90)	37
4 =	13.84 x 39.37 (340 x 1000)	13.84 (340)	15.75 (400)	17.72 (450)	0.95 (24)	1.57 (40)	3.15 (80)	39.37 (1000)	6.69 (170)	25.98 (660)	4.33 (110)	55
5 =	14.96 x 44.09 (380 x 1120)	14.96 (380)	17.32 (440)	19.29 (490)				44.09 (1220)	7.48 (190)	29.13 (740)	5.12 (130)	72
6 =	16.93 x 49.21 (430 x 1250)	16.93 (430)	19.21 (490)	21.26 (540)				49.21 (1250)	8.07 (205)	33.07 (840)	5.31 (135)	93
8 =	20.87 x 63 (530 x 1600)	20.87 (530)	63 (1600)	25.98 (660)	1.1 (28)	1.97 (50)	3.94 (100)	63 (1600)	10.63 (270)	41.73 (1060)	7.09 (180)	192

	Pumpe pump pompe	Motor motor moteur	Kupplung coupling accouplement	Grundplatte base plate socle	Σ
Maße dimensions dimensions [inch] [mm]	Z ₁	Z ₂	Y ₂		L
Gewichte weights poids [kg]					

Baureihe/Series/Série

Ausführung **Magnetkupplungspumpe ASME**

MNKA

Design **Magnet drive pump ASME**



Construction **Pompe à entraînement magnétique ASME**

Modification techniques sans préavis, réservées!
 Graphique non à l'échelle!
 Dimensions variables uniquement revêtues d'une signature!

This leaflet is subject to alteration!
 Drawing not to scale!
 Certified for construction purposes only when signed!

Technische Änderungen vorbehalten!
 Nicht maßstäblich!
 Maße nur mit Unterschrift verbindlich!

Y ₂ = 0.118 inch (3 mm)	Motorbaugröße / motor size / taille de moteur																
Pumpengröße Pump size Taille de pompe	143T	145T	182T	184T	213T	215T	254T	256T	284T	284TS	286T	286TS	324T	324TS	326T	326TS	
1.5"x1"x6"						-											
3"x2"x6"	3					3		-					-				
1.5"x1"x8"							4										
3"x1.5"x8"	4	4							5								
2"x1"x10"	-													6			

Y ₂ = 3.937 inch (100 mm)	Motorbaugröße / motor size / taille de moteur																
Pumpengröße Pump size Taille de pompe	143T	145T	182T	184T	213T	215T	254T	256T	284T	284TS	286T	286TS	324T	324TS	326T	326TS	
1.5"x1"x6"						-											
3"x2"x6"	3					3	4	-					-				
1.5"x1"x8"							4										
3"x1.5"x8"	4	4					5		6								
2"x1"x10"	-													6	8		

Y ₂ = 5.512 inch (140 mm)	Motorbaugröße / motor size / taille de moteur															
Pumpengröße Pump size Taille de pompe	143T	145T	182T	184T	213T	215T	254T	256T	284T	284TS	286T	286TS	324T	324TS	326T	326TS
1.5"x1"x6"						-										
3"x2"x6"	3					4		-					-			
1.5"x1"x8"							4									
3"x1.5"x8"	4	4			5		6									
2"x1"x10"	-											8				

Baureihe/Series/Série

Ausführung **Magnetkupplungspumpe ASME**

MNKA

Design **Magnet drive pump ASME**

Construction **Pompe à entraînement magnétique ASME**



Modification techniques sans préavis, réservées!
 Graphique non à l'échelle!
 Dimensions variables uniquement revêtues d'une signature!

This leaflet is subject to alteration!
 Drawing not to scale!
 Certified for construction purposes only when signed!

Technische Änderungen vorbehalten!
 Nicht maßstäblich!
 Maße nur mit Unterschrift verbindlich!

NEMA-Motor NEMA-motor NEMA-moteur	U ₁ [inch] ([mm])	D [inch] ([mm])	Cmax* [inch] ([mm])	V ₁ [inch] ([mm])
143T	0.875 (22,23)	3.5 (88.9)	12.6 (320)	2.00 (50.8)
145T			13.7 (348)	
182T	1.125 (28.58)	4.5 (114.3)	14.8 (376)	2.5 (63.5)
184T			15.8 (401)	
213T	1.375 (34,93)	5.25 (133,4)	18.2 (462)	3.12 (79,25)
215T			19.6 (498)	
254T	1.625 (41,28)	6.25 (158.8)	23 (584)	3.75 (95.25)
256T			24.8 (630)	
284T	1.875 (47,63)	7.00 (177,8)	26 (660)	4.38 (111,25)
284TS	1.625 (41,28)			3.00 (76,2)
286T	1.875 (47,63)		27.5 (699)	4.38 (111,25)
286TS	1.625 (41,28)			3.00 (76,2)
324T	2.125 (53,98)	8.00 (203.2)	30 (762)	5.00 (127)
324TS	1.875 (47,63)			3.5 (88,9)
326T	2.125 (53,98)			5.00 (127)
326TS	1.875 (47,63)			3.5 (88,9)

*ca. Maße / approx. dimensions / environ mesure

Grundplattengröße Base plate size Taille du socle	[inch] ([mm])
3 =	11.81 x 35.43 (300 x 900)
4 =	13.84 x 39.37 (340 x 1000)
5 =	14.96 x 44.09 (380 x 1120)
6 =	16.93 x 49.21 (430 x 1250)
8 =	20.87 x 63 (530 x 1600)